

A close-up photograph of a leather sofa, showing the texture of the leather and the stitching of a cushion and backrest. The lighting is soft and warm, highlighting the grain of the leather.

**DIVANI
POLTRONE
SOFAS
ARMCHAIRS
MADE
IN ITALY**

CTS
ITALIAN SOFAS

**DIVANI POLTRONE
DAL 1965
SOFAS ARMCHAIRS
SINCE 1965**

COMPANY PROFILE pag.02

COLLEZIONE DIVANI_SOFAS COLLECTION pag.14

COLLEZIONE POLTRONE_ARMCHAIRS COLLECTION pag.118

CONTRACT DIVISION pag.162

TECHNICAL INFORMATION pag.172

CTS
ITALIAN SOFAS

CTS SALOTTI
MILANO



Gianluca, Sabrina e Carlo Tanzi.

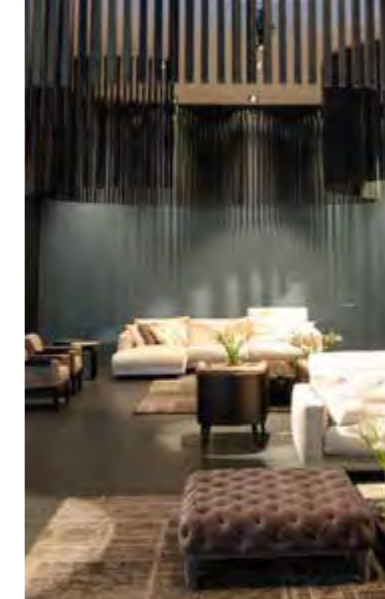

COMPANY PROFILE

UNA STORIA ITALIANA AN ITALIAN STORY

CTS nasce dall'evoluzione di un laboratorio artigianale fondato da Carlo Tanzi a metà degli anni sessanta a Carate Brianza, proprio al centro della Brianza, territorio che rappresenta l'eccellenza del design italiano. La piccola unità produttiva comincia a realizzare imbottiti, poltrone e divani comodi e di alta qualità. Il laboratorio si trasforma in impresa e diventa dopo gli anni settanta un'industria di successo sul mercato italiano. Tutto questo grazie alle idee fervide di Carlo Tanzi e al contributo progettuale e creativo di industrial designers che hanno condiviso la scelta di "design della qualità" iniziata dalla proprietà.

Con l'entrata in azienda dei figli Sabrina e Gianluca, la visione progettuale e la personalità estetica dei prodotti si rinnova e si rafforza a tal punto da costituire una collezione di imbottiti con un più alto grado di expertise, valore determinante per la costruzione di un'immagine internazionale. È proprio da questo punto in poi che le poltrone e i divani CTS non solo diventano protagonisti di storie di design che appartengono a tante case del mondo, ma grazie alla collaborazione con architetti del settore contract, diventano "primi attori" di prestigiosi hotel e spazi collettivi nel mondo.

CTS was established as the evolution of an artisan workshop founded by Carlo Tanzi in the mid-sixties in Carate Brianza, right in the heart of the Brianza territory that represents Italian design excellence. The small production unit began making upholstered furniture - comfortable, fine quality armchairs and sofas. This workshop expanded into a larger business enterprise, then at the end of the seventies, it became a successful industry on the Italian market. All of this thanks to the impassioned ideas of Carlo Tanzi and to the design and creative input from industrial designers who agreed with the owner's decision to go with "quality design". When Carlo's children, Sabrina and Gianluca, joined the company, the design vision and the aesthetic personality of the products were renewed and reinforced and they were turned into a collection of upholstered furniture with a wealth of expertise, a crucial value to build up an international image. This was the point when the CTS armchairs and sofas not only became protagonists of the design stories behind many homes all over the world but, through the collaboration with architects from the contract sector, they also became the "lead players" in prestigious hotels and community spaces throughout the world.



Designer Maurizio Marconato e Terry Zappa.



DESIGN AND PROJECTS

INNOVAZIONE CREATIVA CREATIVE INNOVATION

La ricerca costante di segni e forme in armonia, di materiali, colori e dettagli unici e di design, danno vita ad una collezione emozionante e suggestiva, capace di entrare con originalità in ogni progetto di interiors internazionale.

La ricerca come valore consolidato nel dna dell'azienda che si amplifica con la collaborazione del team creativo dei designers Maurizio Marconato e Terry Zappa.

The ongoing research into harmonious trademarks and shapes, into unique, designer materials, colours and details generate an exciting and expressive collection that can be an original part of any international interior design project. This research is a consolidated value in the company's DNA and it is heightened by the creative design team of Maurizio Marconato and Terry Zappa.



MARCONATO & ZAPPA



CRAFTSMANSHIP

MANI ESPERTE PRODUCONO QUALITÀ EXPERT HANDS PRODUCE QUALITY

Un processo manuale quotidiano, volto alla ricerca di una qualità eccellente in un design sempre originale. CTS realizza ogni prodotto all'interno dell'azienda, enfatizzando la cura dei dettagli e delle finiture. Ogni materiale selezionato è sottoposto a test di verifica per calibrarne la qualità, espressa sempre in termini di resistenza e di durata.

An everyday handcrafted process aimed at the search for excellent quality in a constantly original design.

CTS makes every product in-house, accentuating the care for details and finish. Before being selected, all the materials are tested to calibrate their quality, always expressed in terms of resistance and lifetime.

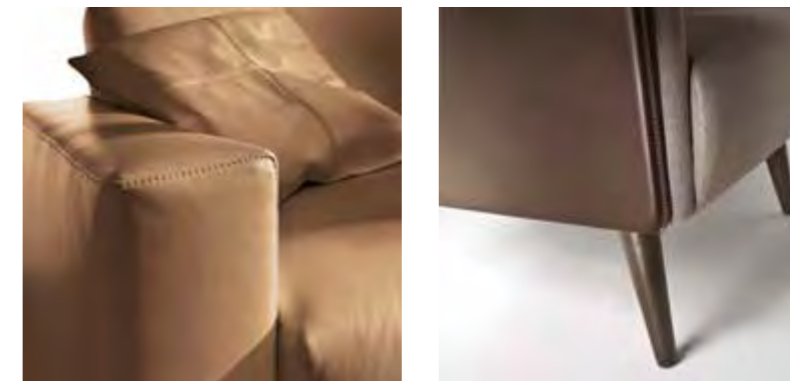

PRECIOUS MATERIALS

L'INESAURIBILE RICERCA DELL'ECCELLENZA THE NEVER-ENDING SEARCH FOR EXCELLENCE

Punto di forza CTS, oltre alla sperimentazione quotidiana ed estetica, è la ricerca formale di materiali di alta qualità.

Da un lato quelli più affascinanti al tatto e alla vista come i tessuti nobili, le pelli pregiate, i legni naturali e gli straordinari marmi; dall'altro quelli eccellenti e nascosti come le resistenti strutture in legno massello, le morbide imbottiture in piuma d'oca Oro e i tecnologici poliuretani espansi.

In addition to everyday experimentation and aesthetics, the strength of CTS lies in its formal research into top quality materials.

On the one hand, materials that are fascinating to touch and look at, including fine fabrics, exceptional leather, natural wood and extraordinary marble; on the other, the excellent and hidden qualities like the strong frames in solid wood, the soft padding in ORO goose down and high-tech polyurethane foam.





Salone del Mobile Milano 2016

INTERNATIONAL BRAND

UN'IDENTITÀ 100% MADE IN ITALY A 100% MADE IN ITALY IDENTITY

La costante, continua e creativa partecipazione alle mostre di settore in particolare al "Salone del Mobile di Milano" con i suoi oltre 40 anni di presenza e a mostre estere come "I Saloni WorldWide di Mosca" hanno portato il brand verso il palcoscenico del mercato globale, con una distribuzione capillare sul territorio italiano e una presenza sempre più ampia sullo scenario internazionale.

The constant, ongoing and creative participation in trade fairs, particularly in the "Salone del Mobile di Milano" where we have been present for over 40 years, and exhibitions abroad like "I Saloni WorldWide di Mosca" has brought the brand onto the global market, with widespread distribution across Italy and expanding more and more into the international scene.



Gianluca Tanzi e Carlo Tanzi



INTERIORS AND CONTRACT DIVISION

PROGETTI PRESTIGIOSI PRESTIGIOUS PROJECTS

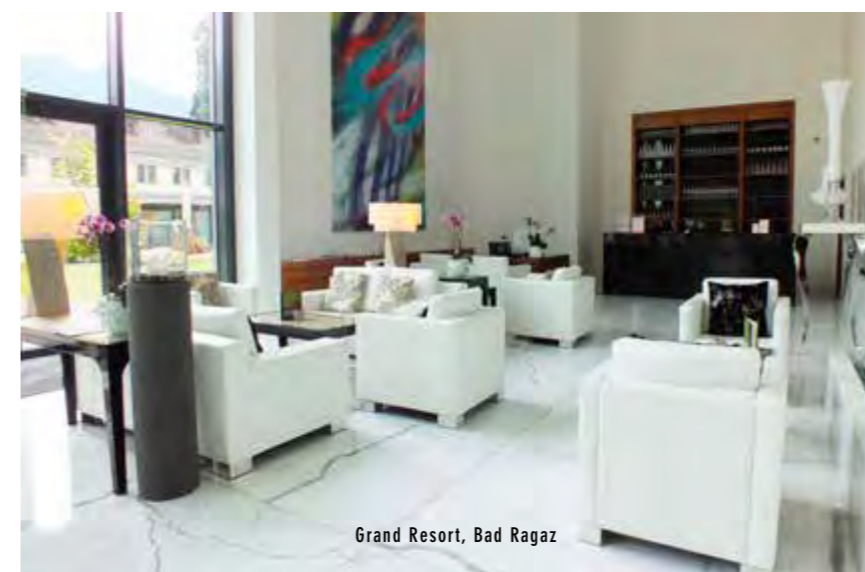

Grand Resort, Bad Ragaz

Lo stile CTS, ha contribuito, sia in Italia che all'estero, a realizzare progetti prestigiosi nell'ambito residenziale e nel settore contract, con particolare attenzione alla collaborazione con studi di architettura per la realizzazione di arredi "customized" per hotel, spazi lounge, ristoranti, negozi e yacht.

In Italy and abroad, the CTS style has helped create prestigious projects in the residential field and in the contract sector, and it has focused a great deal on working with architecture studios to come up with customised furniture for hotels, lounges, restaurants, retail and yachts.



Hotel West Inn, Francoforte

INDICE INDEX

DIVANI_SOFAS



TIME pag.16



FLAP LARGE pag.26



FLAP pag.26



ROGER pag.34



ANDY pag.42



ELLIOT pag.48



PREMIÈRE pag.56



HAVEN pag.62



TAILOR pag.68



PASSION pag.74



LIGHT pag.80



EASY pag.86



OPEN pag.92



SPACE pag.98



WELL pag.104



WELL SOFT pag.108



SMART pag.110

POLTRONE_ARMCHAIRS



TIME pag.120



DANDY pag.122



PLAZA pag.124



REBECCA pag.126



ELLIOT pag.128



ELLIOT pag.129



ELLE pag.130



DANA pag.132



ANNA pag.134



MEGAN pag.136



GLEE pag.138



DIVA pag.140



PASSION pag.142



LIGHT pag.144



EASY pag.146



MOON pag.148



WELL pag.150



HOLA pag.152



COCOON pag.154

TAVOLINI_SMALL TABLE



SELFY pag.156



CHARME pag.158



ELLIOT pag.160

COLLEZIONE DIVANI_SOFAS COLLECTION

**DIVANI
DAL DESIGN CONTEMPORANEO
SOFAS
CONTEMPORARY DESIGN**

TIME

design marconato&zappa

Una linea accogliente e raffinata diventa originale struttura a vista pronta a contenere cuscini di seduta, di schienale e braccioli. Originale base in legno di frassino disponibile in diverse varianti di colore.

A cosy, refined line becomes an original, exposed frame ready to encompass seating, backrest and armrest cushions. Original ash frame available in assorted colours.



Divano e poltroncine Time, tavolini Charme.
Time sofa and armchairs, Charme coffee tables.



Divano e poltroncine Time, tavolini Charme.
Time sofa and armchairs, Charme coffee tables.

STRAORDINARIA FUNZIONALITÀ

Ricerca costante della funzionalità: il divano è stato progettato per un'ampia gamma di soluzioni compositive grazie ai numerosi elementi disponibili.

Constant search for functionality: the sofa is designed for the many components available in this line allow for a wide range of compositions.



Divano Time e tavolino Selty.
Time sofa and Selty coffee table.



Divani Time e tavolini Selfy.
Time sofas and Selfy coffee table.

COMFORT DI CLASSE

Raffinate cuciture a cordoncino impreziosiscono e disegnano il rivestimento in tessuto sfoderabile che accoglie una morbida e accogliente piuma d'oca per un comfort senza confronti.

Refined piping stitch adds a lovely touch and frame the removable fabric cover that embraces soft, cosy goose down for unparalleled comfort.



Divano Time e tavolini Selfy.
Time sofa and Selfy coffee tables.

FLAP LARGE

design marconato&zappa

Design confortevole e decisamente accogliente per Flap, un sistema di sedute fisse e componibili caratterizzato dalla possibilità di alzare e posizionare a piacere la parte alta dello schienale, trasformandola così in un comodo poggia-testa.

A comfortable and unquestionably enveloping design for Flap, a fixed and modular seating system featuring the possibility of raising and positioning the upper part of the backrest to obtain a relaxing headrest.

Divano Flap Large, poltrona Dandy e tavolino Elliot.
Flap Large sofa, Dandy armchair and Elliot small table.





Divano Flap Large e tavolino Elliott.
Flap Large sofa and Elliott small table.



POSIZIONE A PIACERE

Il divano presenta la versione Flap Large con una maggior profondità di seduta e la versione Flap con una profondità più equilibrata e si caratterizza dalla possibilità di sistemare in 10 posizioni la parte alta dello schienale diventando poggia-testa.

The Flap Large variant has a deeper seat, and the Flap sofa has a more balanced depth. The upper part of the backrest can be moved into 10 different positions for use as a headrest.





Divano Flap Large e tavolini Elliot.
Flap Large sofa and Elliot small tables.

MORBIDI CUSCINI

Originale il disegno del bracciolo che nella sua parte interna si presenta sinuoso e morbido come i generosi cuscini in piuma d'oca. Morbidi cuscini di seduta possono essere realizzati in piuma d'oca con inserto in poliuretano oppure completamente in poliuretano. Il sistema è completamente sfoderabile.

The distinctive armrest design features a soft, undulating inner, like the generous down cushions. Soft seat cushions can be made from goose down with polyurethane insert or polyurethane only. The system has fully removable covers.



Divano Flap Large e poltrona Plaza.
Flap Large sofa and Plaza armchair.

ROGER

design marconato&zappa

Roger è un sistema di sedute sfoderabili di grande versatilità compositiva e con una comodità senza confronti grazie al cuscinetto reggischiena posizionato dietro i cuscini schienale. Il design lineare è caratterizzato da un profilo in tinta o tono su tono che esalta il rivestimento in tessuto.

Roger is a highly versatile seating system with removable covers. It offers a wide range of compositions and unparalleled comfort thanks to the support pads set behind the back cushions. The linear design features matching or tone-on tone profile that underscores the fabric cover.

Divano Roger, poltrona Rebecca e tavolino Elliot.
Roger sofa, Rebecca armchair and Elliot small table.

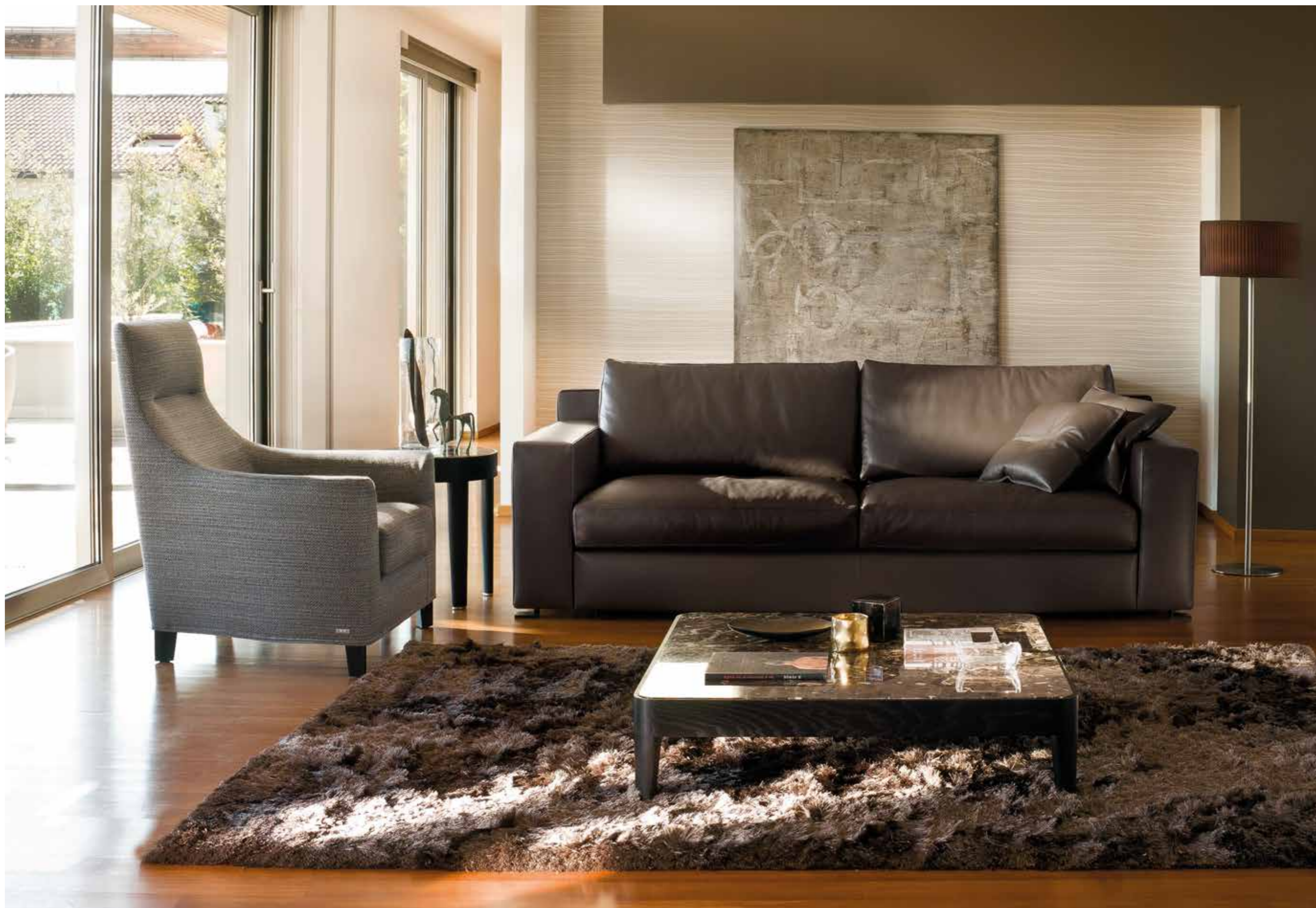

DETTAGLI DI QUALITÀ

Le pelli selezionate CTS garantiscono l'armonia dei toni pur mantenendo leggerissime virature che certificano la bellezza naturale di un rivestimento nobile e di alta resistenza.

The CTS selected leather guarantees harmonious shades while still retaining the slight differences that confirm the natural beauty of a noble, hard-wearing cover.



Divano Roger, poltrona Rebecca e tavolini Elliot.
Roger sofa, Rebecca armchair and Elliot small tables.



Divano Roger, poltrona Elle e tavolino Elliot.
Roger sofa, Elle armchair and Elliot small table.



UN COMODO LETTO

Roger completamente sfoderabile è disponibile nella versione letto, con apertura facilitata e speciale rete ortopedica che lo rende grande e comodo come un vero letto.

Roger, with completely removable cover, also comes as an easy-to-open sofa bed with special orthopaedic slats that provide the same comfort as a real bed.



Divano Roger.
Roger sofa.



ANDY

design marconato&zappa

Segno distintivo di Andy è la raffinata e leggera bombatura del bracciolo che ben si raccorda con la linearità della base in tubolare di alluminio, disponibile in varie finiture.

The distinctive element in Andy is the refined, slightly rounded arm that goes well with the linearity of the tubular aluminum base which comes in various finishes.

Divano Andy.
Andy sofa.

SOFISTICATA ELEGANZA

Andy è diventato subito un classico grazie all'eleganza della proporzione calibrata dei volumi che lo compongono secondo una geometria sofisticata. Anche nella versione con chaise longue mantiene intatto il suo rigore formale.

Andy became an immediate classic due to the elegantly balanced proportions of its volumes, in keeping with a sophisticated shape. The version with chaise longue also keeps its clean lines.

Divano Andy e poltrona Rebecca.
Andy sofa and Rebecca armchair.





SEMPlicità DI APERTURA

Andy, completamente sfoderabile, è disponibile anche, con una semplice apertura, nella versione letto con rete ortopedica a doghe in faggio o rete a maglia e materasso in espanso speciale rivestito in fodera di cotone trapuntato.

Andy, with completely removable cover, also comes in a hideaway bed version that is simple to open with orthopaedic base with beech wood slats or link mesh and mattress in special expanded covered in quilted cotton fabric.



Divano e pouff Andy.
Andy sofa and pouff.

ELLIOT

design marconato&zappa

Personalità unica e carattere ricercato per Elliot, il divano accogliente realizzato con preziosa imbottitura a capitonné. Protagonista sia nella casa moderna che in quella classica.

With a unique, sophisticated personality, Elliot is a comfy sofa that boasts refined capitonné upholstery. Designed to star in any home whether modern or traditional



Divano e poltrona Elliot.
Elliot sofa and armchair.



Divano, poltroncine e pouff Elliot.
Elliot sofa, small chairs and pouff.



LAVORAZIONE CAPITONNÈ

Una collezione preziosa, con straordinarie possibilità arredative. Colpisce il morbido segno dei rombi con al centro il tipico bottone della lavorazione capitonnè.

A refined collection with extraordinary decorating potential. The soft diamond shapes and central button of the capitonnè upholstery process catch the eye.





Divano, poltroncine e pouff Elliot.
Elliot sofa, small chairs and pouff.



ORIGINALI VOLUMI

Elliot si distingue per gli originali volumi curvi e sinuosi dello schienale e dei braccioli.

La collezione è disponibile nelle versioni con basamento imbottito o con basamento in legno di frassino. La progettazione ha considerato un valore importante la possibilità di un montaggio semplice, veloce e per un comodo trasporto.

Elliot stands out for the original curved, sinuous volumes of the back and arms. The collection comes in two versions: with upholstered or ashwood base. The design offers the added value of quick, easy installation and convenient transport.

Divano e chaise longue Elliot.
Elliot sofa and chaise longue.



PREMIÈRE

design marconato&zappa

Première è un sistema di sedute ampio e componibile dal design personale e autorevole, caratterizzato da una comodità senza confronti. Première offre la possibilità di alzare e posizionare a proprio piacimento la parte alta dello schienale trasformandola in un comodo poggia-testa.

Première is a generously deep seating, modular system with a personal, leading design featuring unprecedented comfort. In fact, with Première you can raise and position the top part of the backrest how you like, turning it into a truly relaxing headrest.



Divano Première.
Première sofa.



Divano e pouff Première.
Première sofa and pouff.



RELAX SENZA CONFRONTI

Première è sicuramente un divano dalla comodità superiore grazie alla possibilità di alzare e posizionare la parte alta dello schienale ottenendo un confortevole poggiatesta.

The comfort of the Première sofa is without a doubt superior because it is possible to raise and position the top part of the backrest to obtain a relaxing headrest.

Divano Première e poltrone Moon.
Première sofa and Moon armchairs.



HAVEN

design marconato&zappa

Design senza tempo e accogliente, con una linea decisa e particolare del fianco. Haven è caratterizzato da un alto e comodo schienale e da un originale piedino in metallo verniciato.

A timeless, cosy design with bold, distinctive lines on the side. Haven features a high, comfortable backrest and original foot made of painted metal.

Divano Haven e poltrona Rebecca.
Haven sofa and Rebecca armchair.





Divano e pouff Haven.
Haven sofa and pouff.

Divano Haven e poltrone Moon.
Haven sofa and Moon armchairs.



DESIGN SENZA TEMPO

Haven è un sistema di sedute vario e completo di ampie soluzioni compositive. Il design rassicurante di questo modello consente il suo inserimento in ogni architettura domestica.

Haven è completamente sfoderabile.

Haven is a varied, complete seating system that can be used for many different compositions. Its reassuring design makes it suitable for any domestic architecture.

Haven covers are fully removable.



TAILOR

design marconato&zappa

Tailor si contraddistingue dal design morbido e razionale e da un'ampio e basso schienale. La linea filante si enfatizza grazie all'originale design dei piedini proposti in metallo verniciato.

Tailor is distinguished by its gentle, streamlined design with a broad, low backrest. The sleek line is emphasized by the original design of painted metal feet.

Divano Tailor.
Tailor sofa.



LINEE CONFORTEVOLI

Le qualità di Tailor sono espresse dalla sua immagine rassicurante ma non mancano gli accenti più originali come lo schienale basso e la sua espressione di grande relax nella versione con rivestimento in morbida pelle.

The qualities of Tailor are expressed in its reassuring appearance, but there is no shortage of original accents like the low backrest and its highly relaxing expression in the version with soft leather covering.



Divano Tailor.
Tailor sofa.



Divano Tailor.
Tailor sofa.

VERSATILITÀ COMPOSITIVA

Tailor è un sistema di sedute fisse e componibili con una gamma importante di soluzioni compositive. I cuscini di seduta e di schienale garantiscono un relax senza confronti.

Tailor è completamente sfoderabile, anche nella versione pelle.

Tailor is a system of fixed and modular seats that can be mixed and matched in any number of ways. The seat and the backrest cushions guarantee unparalleled relaxation.

The Tailor has fully removable covers, including for its leather version.





PASSION

esetidesign

Grazie alla sua straordinaria comodità
 Passion è il divano ideale per
 abbandonarsi in un relax senza confronti.
 Contraddistinto da una linea
 morbidamente sinuosa sia del
 fianco, sia dell'ampio bracciolo.

Thanks to its extraordinary
 comfort Passion is the ideal sofa
 for relax without comparison.
 Characterized by the soft lines of its
 side, as with the wide arm rest.

Divano Passion.
 Passion sofa.



Divano e poltrona Passion.
Passion sofa and armchair.



Divano Passion.
Passion sofa.



ACCOGLIENTE E CONFORTEVOLE

Passion propone un vero grande letto matrimoniale con rete ortopedica che si apre con un semplice gesto.

Passion è completamente sfoderabile.

Passion offers a large double bed with an orthopedic base that opens with a simple gesture.

Passion has completely removable upholstery.



LIGHT

design marconato&zappa

Un segno forte e distintivo per una linea veramente innovativa, leggera ed emozionante: è Light, il divano dalle eleganti linee, destinato ad una contemporaneità straordinaria.

A strong, distinctive mark for a truly light, exciting line: this is Light, the sofa with an elegant design for an extraordinary contemporary setting.



Divano e pouff Light.
Light sofa and pouff.



Divano e poltrone Light.
Light sofa and armchairs.

LINEA ELEGANTE E CONTEMPORANEA

Light è soprattutto comodo e generoso, i suoi interni in piuma d'oca conferiscono una presenza autorevole al centro del living domestico. Light è un divano completamente sfoderabile.

Light is primarily comfortable and generously sized; its down-filled inner core adds a leading-edge charisma to the centre of the living room. Light has fully removable covers.



Divano Light.
Light sofa.



EASY

design marconato&zappa

Una linea senza tempo, accogliente e confortevole. Un perfetto equilibrio tra bracciolo e schienale che mantiene un fascino contemporaneo entrando a buon diritto sia nella casa moderna sia in quella tradizionale.

A timeless, enveloping and comfortable line. The armrest and the backrest are perfectly balanced, maintaining contemporary charm to rightly become part of a modern home as well as of a traditionally furnished home.

Divano e pouff Easy.
Easy sofa and pouff.



Divani Easy.
Easy sofas.

DETTAGLI DI ALTA QUALITÀ

Alta qualità in ogni dettaglio: cuscini in morbida piuma con inserto in poliuretano o in poliuretano espanso speciale. Il divano Easy è completamente sfoderabile.

Top quality in every detail: soft, down-filled cushions with polyurethane or special polyurethane inner foam core. The Easy sofa has fully removable covers.

Divano e poltrona Easy.
Easy sofa and armchair.



OPEN

design marconato&zappa

Creatività e fantasia suggeriscono una ampia gamma di soluzioni compositive.

L'elegante curvatura del bracciolo esalta la sua decisa personalità.

Your creativity and originality can be given free rein in a wide range of compositions. Elegantly curved armrests give it a distinctive touch of personality.



Divano e pouff Open.
Open sofa and pouff.



Divano Open.
Open sofa.

CREATIVITÀ E FANTASIA

Una linea sinuosa e raffinata caratterizza il sistema di sedute fisse e componibili Open.

Open presenta una morbida cuscinatura realizzata in piuma d'oca con inserto in poliuretano speciale. Completamente sfoderabile.

Sinuous and sophisticated styling is the key feature of the Open system of fixed and modular seating. The Open sofa has soft goose down cushions with a special polyurethane foam insert. Open has completely removable upholstery.





Divano Open.
Open sofa.



SPACE

design marconato&zappa

Space è un sistema di sedute ad ampia profondità con una vasta gamma di soluzioni compositive. Design morbido e accogliente caratterizzato dalla straordinaria estetica del retro divano caratterizzato da linearità e razionalità.

Space is a generously deep seating system with a wide range of possible compositions. Welcoming design immediately stands out and features the extraordinary design of the sofa back distinguished by linear and rational elegance.

Divano Space.
Space sofa.

GRANDE COMODITÀ

Straordinaria versatilità di soluzioni per Space dal design minimale, che si presenta come prodotto di grande comodità per l'ampiezza della sua profondità.

Extraordinarily versatile solutions for Space a minimal line, offers real comfort with its generous dept.

Divano Space e poltrona Diva.
Space sofa and Diva armchair.





UN LETTO PER TUTTE LE OCCASIONI

Space propone un vero e grande letto matrimoniale che si apre con semplicità, con comoda ed ergonomica rete elettrosaldata. Space è completamente sfoderabile.

Space is simple to open up into a real, large double bed, the key feature of Space is the real bed that comes with a comfortable, ergonomic arc-welded wire base. Space has fully removable cover.

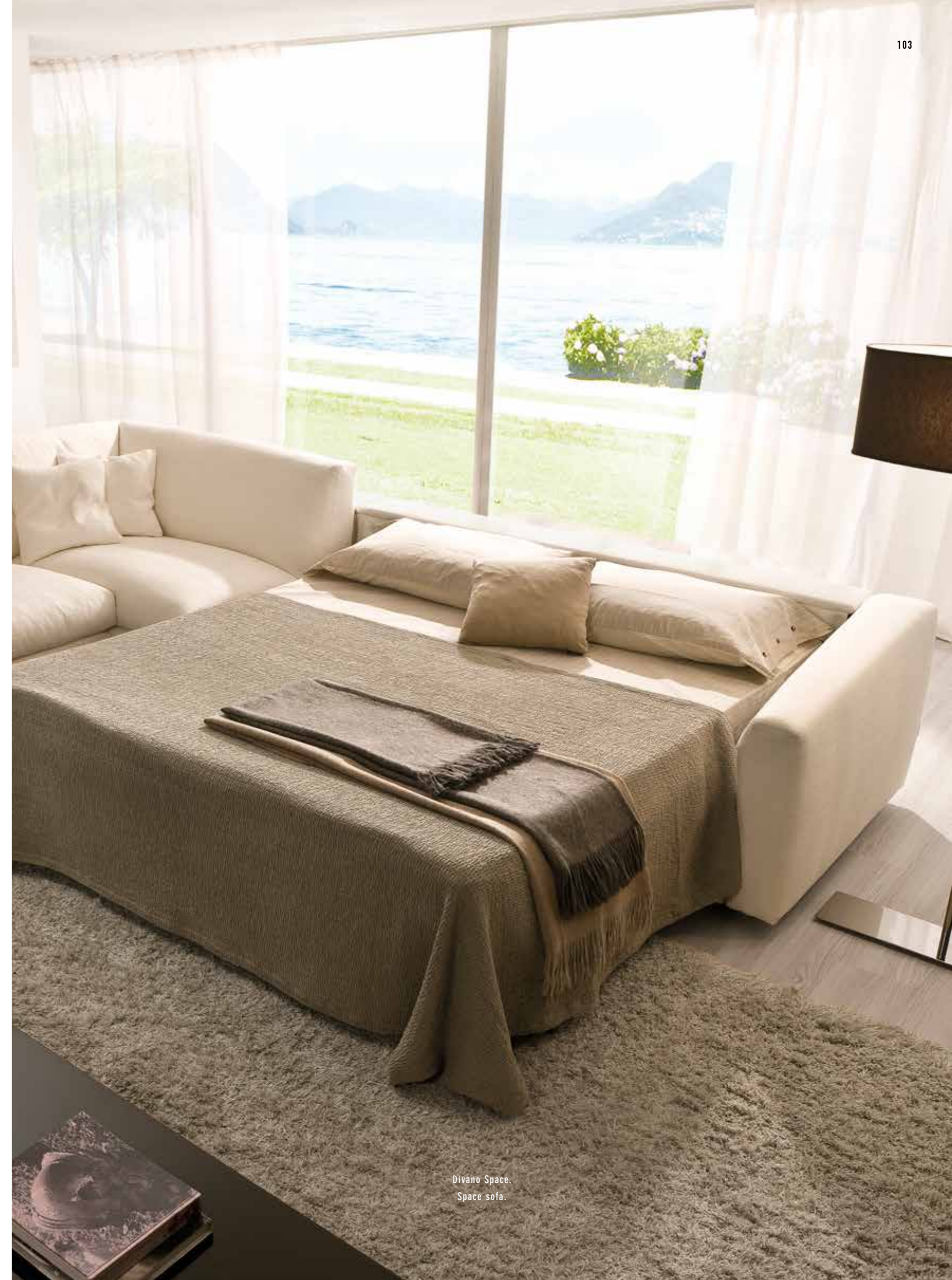

Divano Space.
Space sofa.

WELL WELL SOFT

design marconato&zappa

L'originale linea del fianco con sinuoso poggiatesta conferisce un design esclusivo e di grande comodità al sistema di sedute Well, proposto in due versioni: Well dall'alto cuscino schienale e Well Soft arricchito da piccoli e grandi cuscini.

The original style of the side with a sinuous headrest gives an exclusive and exceptional comfortable design to the Well system of seat, is available in two models: Well by high backrest cushion and Well Soft enriched with small and big cushions.



Divano Well e tavolino Selfy.
Well sofa and Selfy coffee table.



Divano Well e tavolini Selly.
Well sofa and Selly coffee tables.

Divano Well Soft e tavolini Charme.
Well Soft sofa and Charme coffee tables.



WELL SOFT CON COMODI CUSCINI

WellSoft, con schienale arricchito da piccoli e grandi cuscini in morbida piuma. Originale design dei piedini proposti in alluminio satinato, lucido e brunito. Il sistema è completamente sfoderabile.

WellSoft, whose backrest is enriched with small and big cushions filled with soft goose down.

The original foot design can be in satinated, polished or burnished aluminium. All covers are completely removable.

SMART

design marconato&zappa

Un design razionale e lineare ed una particolare lavorazione a doppia cucitura lo caratterizzano.

Smart si propone in due versioni: con cuscini in piuma d'oca e con cuscini in poliuretano.

Characterized by a rational and linear design, Smart stands out for its double stitch pattern construction and is available in two models: with goose down and polyurethane cushions.

Divano Smart.
Smart sofa.





Divano e pouff Smart.
Smart sofa and pouff.

AMPIA COMPONIBILITÀ

Smart è un sistema di sedute sfoderabili di grande versatilità compositiva con un alto grado di comodità. La versione in poliuretano è disponibile all'inserimento di un comodo letto con rete ortopedica.

Smart is a system of extremely comfortable seats with removable covers, allowing a wide range of solutions. The polyurethane version model allowing to accommodate a comfortable bed.



Divano Smart.
Smart sofa.

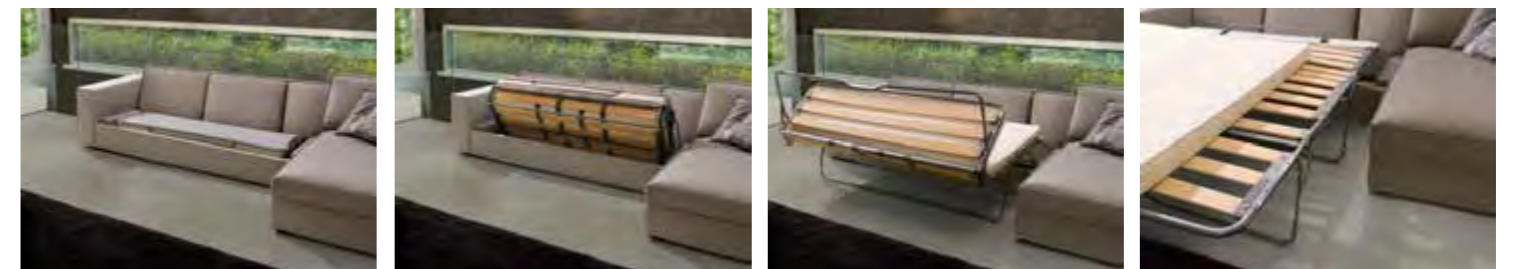

CUSCINI DOUBLE FACE 50X50 CM CON PROFILO
 DOUBLE SIDED CUSHIONS WITH PROFILE (50X50)



CUSCINO CON PROFILO IN TINTA
 CUSHION WITH MATCHING PROFILE

Rivestimento tinta unita 1520/072 cat. EXTRALUX
 Rivestimento quadretti 1510/01 cat. EXTRALUX



CUSCINO CON PROFILO IN TINTA
 CUSHION WITH MATCHING PROFILE

Rivestimento tinta unita 1520/092 cat. EXTRALUX
 Rivestimento quadretti 1510/03 cat. EXTRALUX



CUSCINO CON PROFILO IN CONTRASTO 46 FERRO
 CUSHION WITH CONTRASTING PROFILE 46 FERRO

Rivestimento tinta unita 1520/010 cat. EXTRALUX
 Rivestimento quadretti 1510/04 cat. EXTRALUX



CUSCINO CON PROFILO IN CONTRASTO 1520/010 CAT.EXTRALUX
 CUSHION WITH CONTRASTING PROFILE 1520/010 CAT.EXTRALUX

Rivestimento tinta unita 1520/089 cat. EXTRALUX
 Rivestimento dama 1520/010 e 1520/89 cat. EXTRALUX



CUSCINO CON PROFILO IN TINTA
 CUSHION WITH MATCHING PROFILE

Rivestimento tinta unita 1520/048 cat. EXTRALUX
 Rivestimento quadretti 1510/03 cat. EXTRALUX



CUSCINO CON PROFILO IN TINTA
 CUSHION WITH MATCHING PROFILE

Rivestimento tinta unita 1520/151 cat. EXTRALUX
 Rivestimento quadretti 1510/02 cat. EXTRALUX



CUSCINO CON PROFILO IN TINTA
 CUSHION WITH MATCHING PROFILE

Rivestimento tinta unita 1520/142 cat. EXTRALUX



CUSCINO CON PROFILO IN TINTA
 CUSHION WITH MATCHING PROFILE

Rivestimento Pelle Cristal 25 moka cat. ANILINA

COLLEZIONE POLTRONE_ARMCHAIRS COLLECTION

POLTRONE
PER UN MORBIDO RELAX
ARMCHAIRS
FOR A SOFT RELAXATION



TIME

design marconato&zappa

Il suo equilibrio estetico nasce dalla riduzione di qualsiasi elemento superfluo e dalla costruzione ben proporzionata dalle sue componenti: la linea continua di struttura accoglie in armonia i cuscini pensati e disegnati con rassicurante essenzialità.

Its aesthetic balance is generated by the removal of everything superfluous and by the well-proportioned make of its components: the streamlined structure harmoniously encompasses the cushions, visualised and designed with reassuring essentialism.

DANDY

design marconato&zappa

Dandy è una poltrona che si caratterizza dal tavolino in legno del bracciolo per un comodo appoggio, ed è realizzato con un basamento in legno.

Dandy is an armchair that features a table-top timber armrest for a handy support surface, and a wooden base.





PLAZA

design marconato&zappa

Poltrona dal design contemporaneo
con una forma curva della
struttura che può essere rivestita
in cuoietto, pelle e tessuto.

Contemporary design sofa with
a curved frame that can be
covered with cuoietto leather,
leather and fabric.





REBECCA

design marconato&zappa

Rebecca è una poltrona che consente il comodo appoggio della testa, ed è realizzata con piedini o basamento girevole.

Rebecca is an armchair that offers comfort support for the head. Comes with feet or swivel base.





ELLIOT

design marconato&zappa

Poltroncina con lavorazione a capitonnè disponibile nella versione completamente imbottita o nella versione con basamento in legno di frassino in sei varianti di finitura. Elegante chaise longue con lavorazione capitonnè, disponibile nella versione completamente imbottita o nella versione con basamento in legno di frassino in sei varianti di finitura.

Small chair with capitonnè upholstery.

Comes in two versions: fully upholstered or with ashwood base in six different finishes.

Elegant chaise longue with capitonnè upholstery. Comes in two versions: fully upholstered or with ashwood base in six different finishes.





ELLE

esetidesign

Poltrona dallo stile contemporaneo che si abbina in modo armonico con tutti i divani, realizzata in due versioni di basamento: fisso in legno di frassino tinto o girevole in metallo cromato lucido.

Contemporary style that goes well with all the sofas in the line. Comes with two different bases: stained ashwood fixed or glossy chrome swivel base.

DANA

esetidesign

Elegante e comoda poltrona
con due basamenti a scelta:
fisso in legno di frassino tinto
naturale, noce, noce scuro, wengè o
laccato poro aperto bianco o nero,
girevole in metallo cromato lucido.

This elegant, comfortable armchair
comes with two bases: fixed in ashwood
natural, walnut, dark walnut or wenge
stain or white/black open-pore lacquer,
or swivel base glossy chrome.





ANNA

esetidesign

Poltrona versatile che si adatta in tutta la casa. Due basamenti a scelta: fisso in legno di frassino tinto naturale, noce, noce scuro, wengè o laccato poro aperto bianco o nero e girevole in metallo cromato lucido.

Versatile armchair that's perfect for any room. Choice of two bases: fixed in ashwood natural, walnut, dark walnut or wenge stain or white/black open-pore lacquer or swivel base glossy chrome.



MEGAN

esetidesign

Poltrona dal design contemporaneo con a scelta due basamenti: fisso in legno di frassino tinto naturale, noce, noce scuro, wengè o laccato poro aperto bianco o nero, e girevole in metallo cromato lucido.

This contemporary armchair comes with two different bases: fixed in ashwood natural, walnut, dark walnut or wenge stain or white/black open-pore lacquer, and swivel base with glossy chrome.



GLEE

design marconato&zappa

Poltrona con cuscini in poliuretano speciale. Completamente sfoderabile. Piedini in metallo verniciato colore bianco, brun sablè, grigio e nero.

Armchair with cushion in special polyurethane. All covers are completely removable. Painted metal feet in the following finishes: white, sandy brown, grey and black.





DIVA

design marconato&zappa

Poltrona caratterizzata da basamento
girevole in acciaio lucido o satinato
oppure piedini in legno tinto.
Rivestimento completamente sfoderabile.

Armchair with base rounded in polished
or brushed steel, or feet in tinted wood.
All covers are completely removable.

PASSION

esetidesign

Imbottitura cuscini schienale e sedile
nella versione poliuretano speciale o
in piuma. Completamente sfoderabile.

Piedini in legno di faggio tinto.

Backrest and seat cushions padding
in polyurethane type or feather type.
All covers are completely removable.

Feet in tinted beech-wood.



LIGHT

design marconato&zappa

Rivestimento in pelle o tessuto completamente sfoderabile. Piedini in alluminio lucido o faggio naturale sbiancato o tinto: wengè, noce, noce scuro e ciliegio.

All covers are completely removable. Polished aluminium feet or in beech-wood natural bleached or tinted: wengè, walnut, dark walnut, cherry.



EASY

design marconato&zappa

Una linea senza tempo, accogliente e confortevole. Piedini in alluminio lucido o faggio naturale sbiancato o tinto wengè, noce, noce scuro e ciliegio. Rivestimento completamente sfoderabile.

A timeless, enveloping and comfortable line. Polished aluminium feet or in beech-wood natural bleached or tinted wengè, walnut, dark walnut, cherry. All covers are completely removable.





MOON

design marconato&zappa

Poltrona con basamento in frassino naturale sbiancato o tinto wengè, noce, noce scuro, ciliegio e laccato bianco o nero. Rivestimento completamente sfoderabile.

Armchair with base in ash-wood natural bleached or tinted wengè, walnut, dark walnut, cherry and white or black lacquered. All covers are completely removable.

WELL

design marconato&zappa

Poltrona caratterizzata da cuscini schienale e seduta in poliuretano speciale. Completamente sfoderabile. Piedini in alluminio satinato, lucido e brunito.

Armchair with backrest and seat cushions in special polyurethane. All covers are completely removable. The foot in satined, polished or burnished aluminium.



HOLA

design marconato&zappa

Poltrona caratterizzata da basamento cromato o verniciato, oppure rivestito in cuoio. Rivestimento in pelle o tessuto completamente sfoderabile.

Armchair characterized by base in chrome or painted, alternatively leather-covered. Fully removable leather or fabric cover.





COCOON

design marconato&zappa

Basamento in acciaio lucido oppure
 piedini in alluminio o in legno
 naturale sbiancato o tinto:
 wengè, noce, noce scuro, ciliegio.
 Completamente sfoderabile.

Base in polished steel or feet
 in aluminium or wood: natural
 bleached or tinted wengè, walnut,
 dark walnut, cherry. All covers
 are completely removable.



TAVOLINO
SELFY

design marconato&zappa

Un'essenziale perfezione di materiali tra loro armonici per i raffinati tavolini Selfy che presentano originali piani in marmo Calacatta, marmo Emperador, marmo Portoro e in legno impiallacciato frassino tinto, elegantemente appoggiati a un'inedita base in metallo disponibile nelle finiture bronzo, ottonato anticato, verniciato bronzo scuro anodizzato e verniciato oro satinato.

An essential perfection of harmoniously blended materials for the refined Selfy side tables, with original Calacatta marble, Emperador marble, Portoro marble and painted ash veneer tabletops, which elegantly rest on an innovative metal base available in a bronze, antique brass, painted dark bronze anodized and painted gold satin finish.





TAVOLINO
CHARME

design marconato&zappa

Una collezione di tavolini caratterizzata da un'immagine importante e leggera grazie alla struttura della base in metallo in quattro finiture bronzo, ottonato anticato, verniciato bronzo scuro anodizzato e verniciato oro satinato, che sostiene rigorosi piani d'appoggio in marmo nelle versioni Calacatta, Emperador e Portoro, e in legno impiallacciato frassino tinto.

A collection of side tables featuring a bold and light look thanks to the metal base in four finishes - bronze, antique brass, painted dark bronze anodized and painted gold satin finish - that support streamlined original Calacatta marble, Emperador marble, Portoro marble and painted ash veneer tabletops.





TAVOLINO
ELLIOT

design marconato&zappa

La linea elegante dei tavolini Elliot, caratterizzati da basamento in legno impiallacciato frassino tinto e prezioso piano in marmo, diventa protagonista a fianco dei divani della collezione CTS.

The elegant line of the Elliot side tables, featuring a painted ash veneer base and fine marble table-top, is a stand-out feature alongside the sofas from the CTS collection.



CTS CONTRACT



**PROGETTI CTS
REALIZZATI NEL MONDO
CTS PROJECTS
REALIZED AROUND THE WORLD**

ALBERGHI_HOTELS
AREA LOUNGE_LOUNGE AREA
NEGOZI_STORES
IMBARCAZIONI_YACHT
RISTORANTI_RESTAURANTS



GRAND RESORT BAD RAGAZ

LUSSUOSA ATMOSFERA LUXURIOUS ATMOSPHERE

Circondato dai vigneti e ai piedi delle Alpi, la lussuosa atmosfera dell'hotel e spa offrono spaziosi balconi che permettono una vista a 360° di tutto il panorama. Le suite e la suite presidenziale meglio conosciuta come la "Penthouse Floor" sono di ultima generazione con arredi e dettagli unici per il massimo confort. Progetto realizzato dallo studio di architettura Carbone design. Nella suite sono state inserite poltroncine HOLA e divani SMART realizzati su misura.



Surrounded by vineyards, at the foot of the Alps, the luxurious atmosphere of this hotel and spa includes spacious balconies for uninterrupted scenic views. The new generation suites and the presidential suite, better known as the "Penthouse Floor", boast unique furnishings and details for maximum comfort. The project is by Carbone design architecture studio. The HOLA armchairs and SMART sofas have been customised for the suite.





SUPERIOR GOLF PARK KHARKOV UKRAINA

GIOIELLO SENZA TEMPO TIMELESS GEM

Diamante di stile e di lusso questo primo hotel boutique in Kharkov è unico nel suo genere. Tutte le camere sono uniche nel loro stile e sono affiancate da un'accoglienza veramente incredibile. Progetto realizzato dallo studio di architettura Unis Group. Nelle Suites sono stati inseriti divani, poltrone SMART realizzate su misura. Nell'area lobby sono stati realizzati divani e poltrone CHANTAL, divani OASI e poltrone TOUR.

This stylish, luxury diamond of a boutique hotel in Kharkov is one of a kind. All the rooms have their own unique style and are backed up by truly incredible hospitality. The project is by Unis Group architecture studio. The SMART sofas and armchairs have been customised for the suites. The lobby has been furnished with CHANTAL sofas and armchairs, OASI sofas and TOUR armchairs.





HOTEL CASTELLO DEL SOLE ASCONA

MORBIDA ELEGANZA SOFT ELEGANCE

Il lussuoso hotel a 5 stelle Castello del Sole di Ascona è posizionato sul lago Maggiore permettendo così di avere una preziosa posizione sia per il relax che per meeting di business. Progetto realizzato dallo studio di architettura Carbone design. Nelle camere sono stati inseriti su progetto divani EASY.

The luxury, 5-star Castello del Sole hotel in Ascona is located on Lake Maggiore, in a perfect position for both relaxing and holding business meetings. The project is by Carbone design architecture studio. The design embraced EASY sofas for the rooms.



BRASSERIE Ö STERNER ZURICH

OTTIMO MENÙ EXCELLENT MENU

Il ristorante Brasserie Ö offre i migliori piatti del posto in un ambiente raffinato e arredato per il piacere di rimanere comodamente seduti. Progetto realizzato dallo studio di architettura Dossegger + Mark. In questo progetto sono stati inseriti poltrone, pouff e divani Chester realizzati su misura, sedie e sgabelli sono realizzati su disegno dello studio di architettura.

The Brasserie Ö restaurant delivers the finest cuisine in the area, in refined surroundings furnished for the pleasure of comfortable seating. The project is by Dossegger + Mark architecture studio. Chester armchairs, footstools and sofas were customised for this project, seats and stools were made to the design of the architecture studio.





YACHT

STILE UNICO E DI DESIGN UNIQUE, DESIGNER STYLE



Le nostre soluzioni includono fornitura di contract per barche private/yacht. Attraverso lo studio di esperti di design o direttamente da vostri disegni, i nostri prodotti si adattano allo spazio donando stile unico e di design. Progetto realizzato dallo studio di architettura Lobanov Design. Nella zona living room e nella zona spa sono stati inseriti divani, e poltrone GINSENG realizzati su misura.

Our solutions include contract supplies for private boats and yachts. We use the work of our design experts or your own designs to adapt our products to the space, giving it a unique, designer style. The project is by Lobanov Design architecture studio. The GINSENG sofas and armchairs have been customised for the living area and spa zone.



Una raffinata residenza dalle atmosfere sofisticate, incastonata in una delle perle alpine svizzere più prestigiose, rivela un ampio e contemporaneo living, progettato dallo studio di architettura Carbone design, dove spicca la qualità estetica e realizzativa della collezione divani e poltrone su misura CTS.

A refined home with a sophisticated ambience, set in one of the most prestigious gems in the Swiss Alps reveals a large, modern living zone designed by Carbon design architecture studio, showcasing the stand-out aesthetic and manufacturing quality of the customised CTS sofa and armchair collection.



RESIDENZA PRIVATA ST.MORITZ

LIVING CONTEMPORANEO MODERN LIVING



DIVANI_SOFAS

TIME pag.174

FLAP LARGE pag.176

ROGER pag.178

ANDY pag.180

ELLIOT pag.182

PREMIÈRE pag.184

HAVEN pag.186

TAILOR pag.188

PASSION pag.190

LIGHT pag.192

EASY pag.194

OPEN pag.196

SPACE pag.198

WELL_WELL SOFT pag.200

SMART pag.202

POLTRONE_ARMCHAIRS

TIME pag.204

DANDY pag.205

PLAZA pag.206

REBECCA pag.207

ELLIOT pag.208

ELLE pag.209

DANA pag.210

ANNA pag.211

MEGAN pag.212

GLEE pag.213

DIVA pag.214

PASSION pag.215

LIGHT_EASY pag.216

MOON pag.217

WELL pag.218

HOLA pag.219

COCOON pag.220

TAVOLINI_SMALL TABLES

SELY pag.221

CHARME pag.222

ELLIOT pag.223

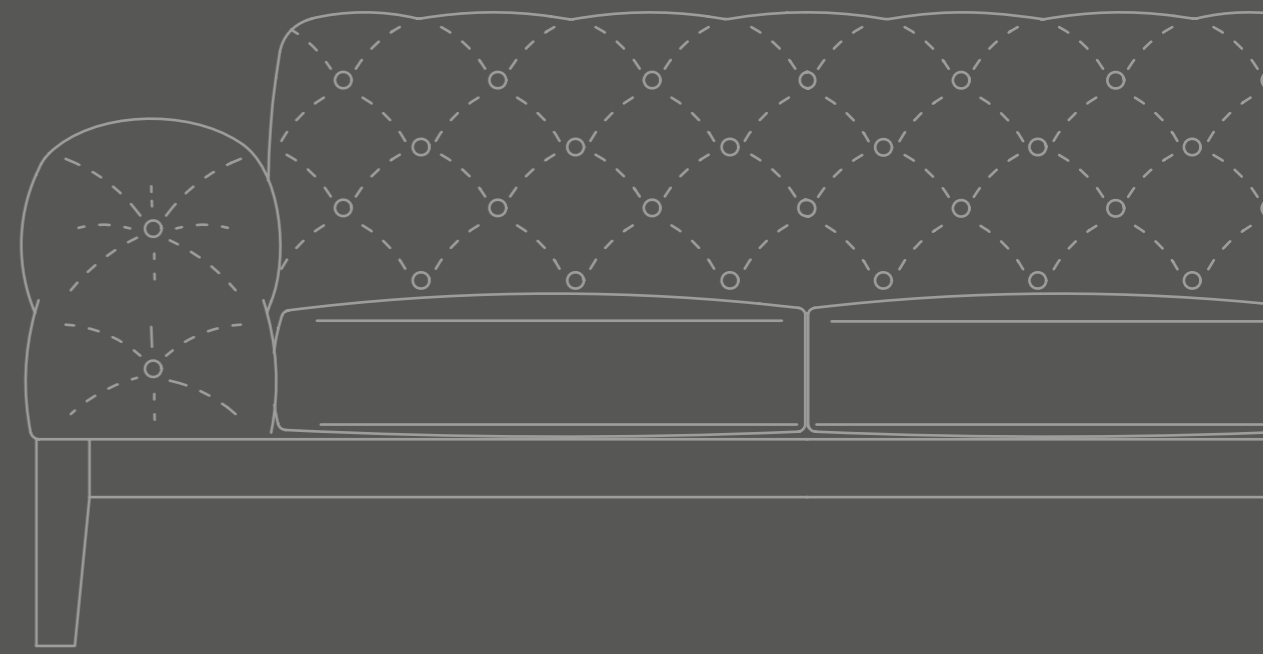
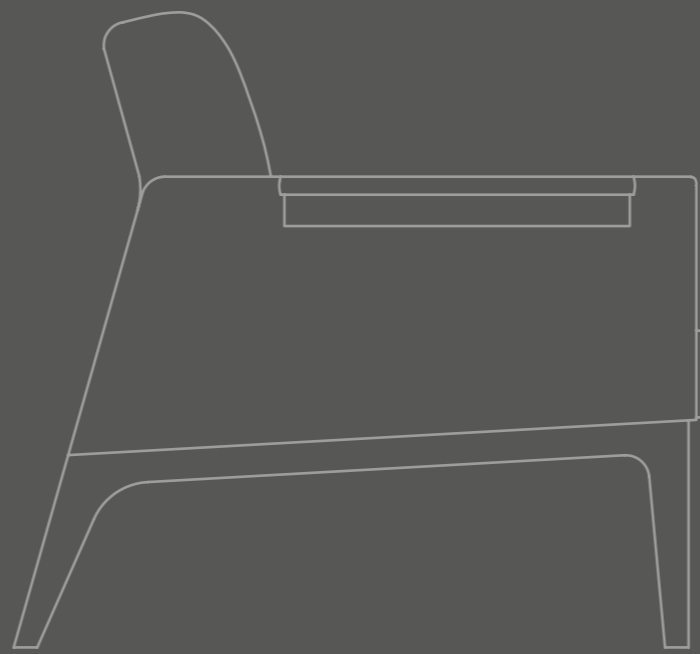

INFORMAZIONI TECNICHE TECHNICAL INFORMATIONS

TIME

design marconato&zappa

Struttura: 1 _Struttura in multistrato di pino mm 30.
2 _Molleghio ottenuto con cinghie elastiche Intes Elabelt 790/S larghezza mm 90.
Imbottitura della struttura: 3 _Poliuretano espanso a densità differenziata T75 e T25. **4** _Resinato accoppiato con vellutino gr 200.
Imbottitura dei cuscini versione piuma: 5 _Cuscino schienale in piuma d'oca SMOB 10 con inserto in poliuretano espanso a densità differenziata T30 e T21 piumex rivestito con fodera pelleovo di cotone. **6** _Cuscino sedile in piuma d'oca SMOB 10 con inserto in poliuretano espanso a densità differenziata T30 e T40 rivestito con fodera pelleovo di cotone. **7** _Cuscino bracciolo in poliuretano espanso T40 rivestito con termolegato accoppiato con tela 200 gr.
Imbottitura dei cuscini versione poliuretano: 5 _Cuscino schienale in poliuretano espanso a densità differenziata SH30 e T21 SS rivestito con fibra di Dacron 400 gr accoppiato con tela di cotone. **6** _Cuscino sedile in poliuretano espanso a densità differenziata T35 Eucalipto e T30 SM rivestito con fibra di Dacron 400 gr accoppiato con tela di cotone. **7** _Cuscino bracciolo in poliuretano espanso T40 rivestito con termolegato accoppiato con tela 200 gr.
Rivestimento: 8 _Rivestimento in pelle o in tessuto completamente sfoderabile.
Finiture: 9 _Basamento in frassino tinto naturale, noce, noce scuro, wengé, bianco poro aperto e nero poro aperto.

Structure: 1 _Poplar plywood frame (30 mm).
2 _Elastic webbing suspension (90 mm wide, Intes Elabelt 790/S).
Structure padding: 3 _Differentiated density polyurethane foam (T75 and T25).
4 _Resin (200 gr) coupled with velveteen.
Cushion padding goose down type: 5 _Back cushion in SMOB 10 goose down with differentiated density polyurethane foam (T30 and T21 piumex) covered with fine muslin. **6** _Seat cushion in SMOB 10 goose down with differentiated density polyurethane foam (T30 and T40) covered with fine muslin. **7** _Armrest cushion in polyurethane foam (T40) covered with Heat-bonded fibre (200 gr) coupled with cotton fabric.
Cushion padding polyurethane type: 5 _Back cushion in differentiated density polyurethane foam (SH 30 and T21 SS), covered with Dacron (400 g) coupled with cotton fabric. **6** _Seat cushion in differentiated density polyurethane foam (T35 Eucalipto and T30 SM), covered with Dacron (400 g) coupled with cotton fabric. **7** _Armrest cushion in polyurethane foam (T40) covered with Heat-bonded fibre (200 gr) coupled with cotton fabric.
Cover: 8 _Fully removable leather or fabric cover.
Finishing: 9 _Base in ash wood - natural, walnut, dark walnut or wenge stain or white or black open-pore lacquer.

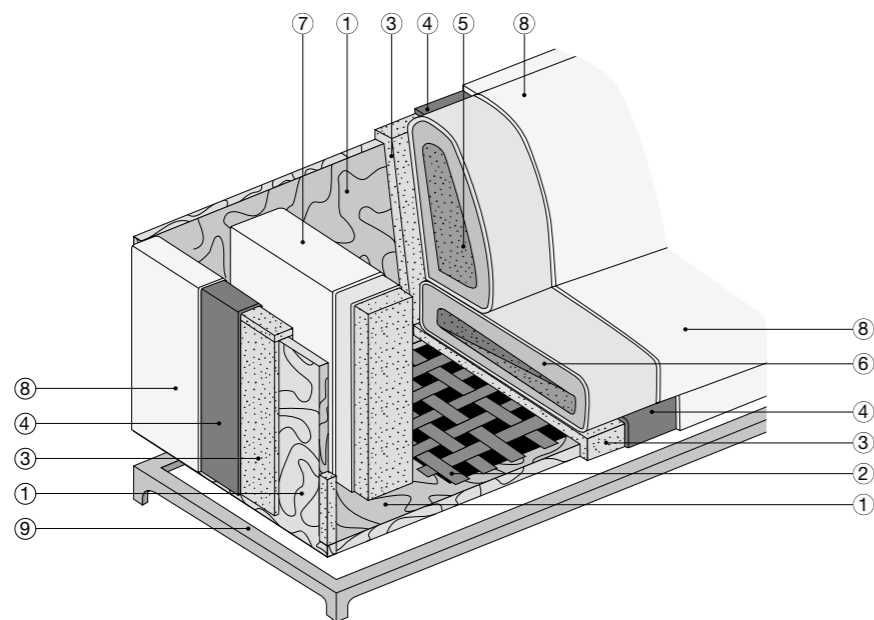

Composizione pagine 16/17 - 18/19

Divano Time: rivestimento pelle Nabuk 15 e basamento frassino tinto noce scuro
 Poltroncine Time: rivestimento 1590/92 cat. EXTRA profilo moro 99 e basamento frassino tinto noce scuro
 Tavolini Charme: piano marmo Emperador e basamento bronzo ottonato

Composizione pagine 22/23

Divano Time: rivestimento 1580/92 cat. EXTRA profilo moro 99 e basamento frassino tinto noce scuro
 Divano Time: rivestimento pelle Cristal 25 cat. ANILINA e basamento frassino tinto noce scuro
 Tavolini Sely: piano marmo Emperador e basamento bronzo ottonato

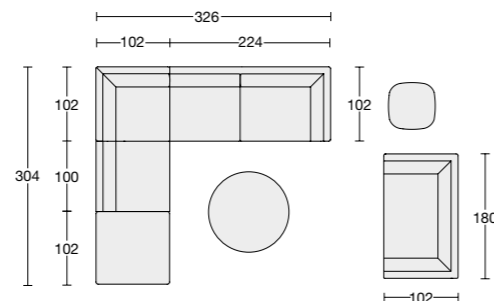
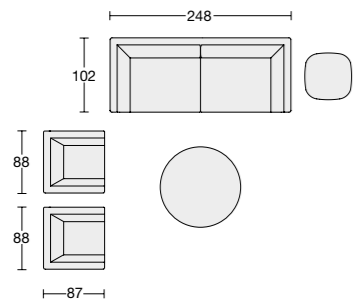

Composizione pagine 24/25

Divano Time: rivestimento 1570/08/01 cat. EXTRA e basamento frassino tinto noce
 Tavolini Sely: piano marmo Calacatta e basamento bronzo

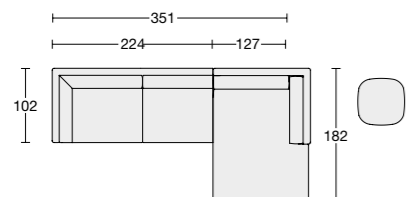

TIME 705/706



Varianti basamento

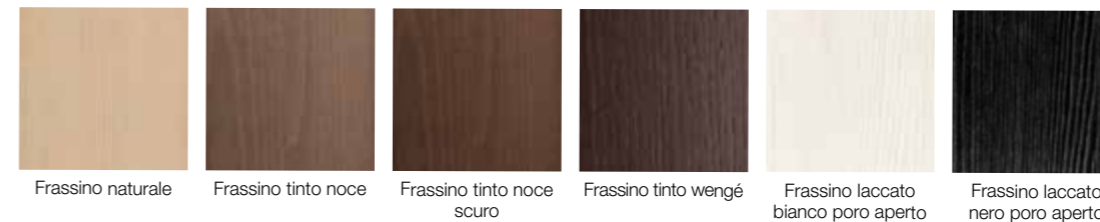

Varianti colori profilo

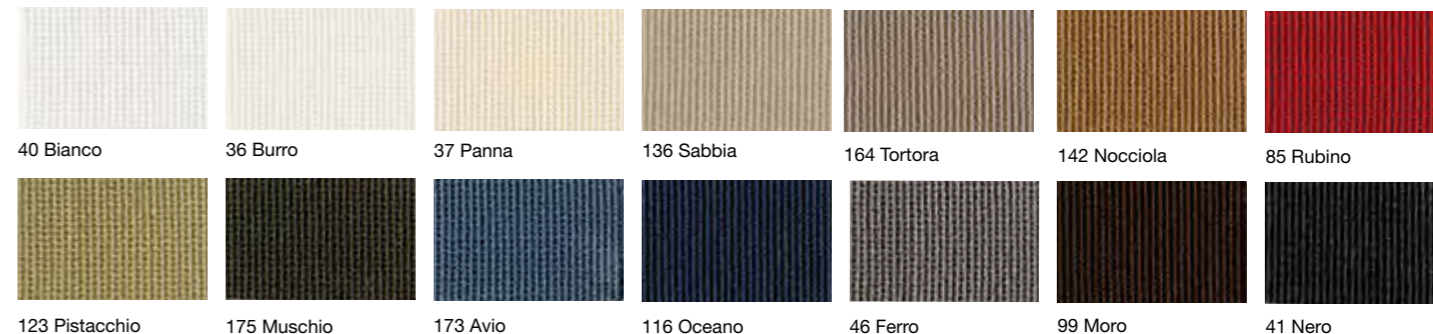

FLAP LARGE_FLAP

design marconato&zappa

Caratteristiche: Il divano si presenta nella versione Flap Large con una maggior profondità di seduta e nella versione Flap con una profondità più equilibrata, e si caratterizza dalla possibilità di sistemare in 10 posizioni la parte alta dello schienale diventando poggiatesta. Morbidi cuscini di seduta possono essere realizzati in piuma d'oca con inserto in poliuretano oppure completamente in poliuretano. Il sistema è completamente sfoderabile.

Struttura: 1_Structura in legno di abete. 2_Pannelli di legno compensato. 3_Pannello in legno multistrati. 4_Molle per il sedile ottenuto con cinghie elastiche Elabest 790/4 mm 90. 5_Meccanismo per movimento parte alta dello schienale funzione poggiatesta.

Imbottitura della struttura: 6_Poliuretano espanso a densità differenziate T25 e T75. 7_Resinato 100 gr accoppiato con vellutino.

Imbottitura dei cuscini versione piuma: 8_Cuscino sedile in piuma d'oca con inserto in poliuretano espanso a densità differenziate T35 e T30 SM rivestito in pelleovo di cotone. 9_Cuscino schienale in poliuretano a densità differenziata PF25 SM, OS30 FM T40 F e MTP95 rivestito con fibra di dacron 400 gr accoppiato con tela di cotone. 10_Poggiareni in piuma d'oca.

Imbottitura dei cuscini versione poliuretano: 8_Cuscino sedile in poliuretano espanso a densità differenziate T35 PF e T40 rivestito con Termolegato 400 gr accoppiato con tela di cotone. 9_Cuscino schienale in poliuretano a densità differenziata PF25 SM e OS30 FM T40 F e MTP95 rivestito con fibra di dacron 400 gr accoppiato con tela di cotone. 10_Cuscino poggiatesta in piuma d'oca.

Rivestimento: 11_Rivestimento in pelle o in tessuto completamente sfoderabile.

Finiture: 12_Piedino in alluminio: lucido, satinato o verniciato nei colori brun sablé, nero e bianco.

Characteristics: The Flap Large variant of the sofa has a deeper seat, and the Flap sofa has a more balanced depth. The upper part of the backrest can be moved into 10 different positions for use as a headrest. Soft seat cushions can be made from goose down with polyurethane insert or polyurethane only. The system has fully removable covers.

Structure: 1_Fir wood frame. 2_Plywood panels. 3_Engineered wood panel. 4_Elastic belt suspension (Elasbelt 790/4 mm 90). 5_Mechanism to move the upper part of the backrest for use as a headrest.

Structure padding: 6_Differentiated density polyurethane foam (T25 and T75). 7_Resin (100 gr) coupled with velvet.

Cushion padding goose down type: 8_Seat cushion in goose down with differentiated density polyurethane foam (T35 and T30 SM) covered with fine muslin. 9_Back cushion in differentiated density polyurethane (PF25 SM, OS30 FM T40 F and MTP95) covered with Dacron fibre (400 gr) coupled with cotton fabric. 10_Lower back cushion in goose down.

Cushion padding polyurethane type: 8_Seat cushion in differentiated density polyurethane foam (T35 PF and T40) covered with Heat-bonded fibre (400 gr) coupled with cotton fabric. 9_Back cushion in differentiated density polyurethane (PF25 SM, OS30 FM T40 F and MTP95) covered with Dacron fibre (400 gr) coupled with cotton fabric. 10_Lower back cushion in goose down.

Cover: 11_Leather or fully removable fabric cover.

Finishing: 12_Aluminium feet in finishes: polished, satin or painted in sandy brown, black and white.

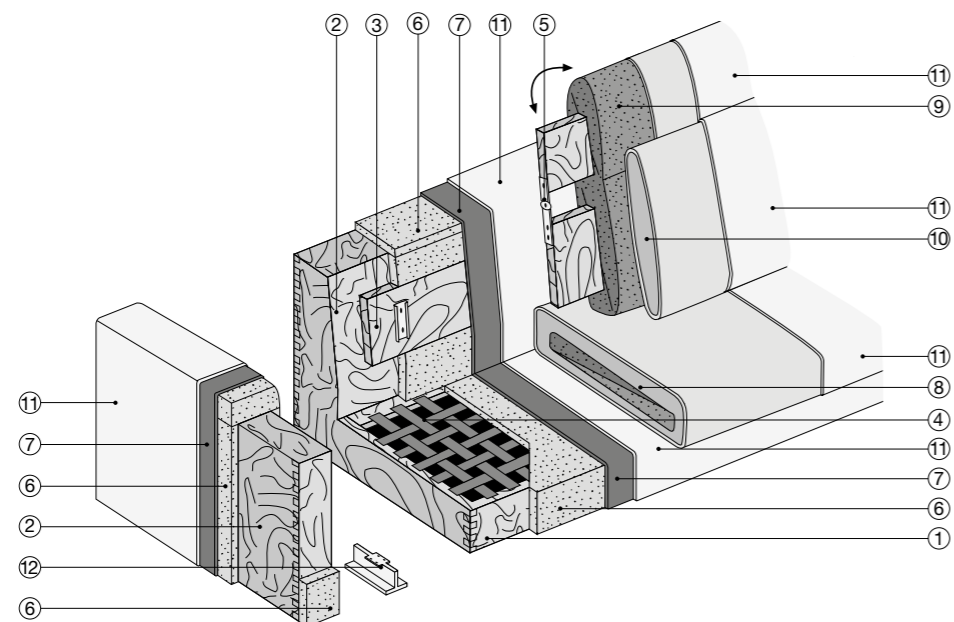

Composizione pagine 26/27 - 28/29

Divano Flap Large: rivestimento pelle Nabuk 14 visone e piedini brun sablé
Poltrona Dandy: rivestimento 1550/1/12 cat. EXTRA basamento tinto wengé

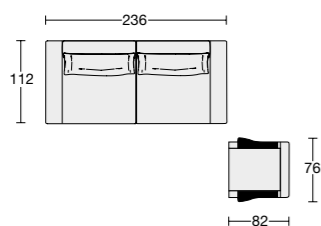

Composizione pagine 30/31

Divano Flap Large: rivestimento 1530/1 cat. H e piedini colore nero



Composizione pagina 32

Divano Flap Large: rivestimento 1550/3/2 cat. EXTRA e piedini colore nero
Poltrona Plaza: struttura e piedini in cuoietto colore testa di moro, cuscini rivestimento 1520/90 cat. EXTRALUX

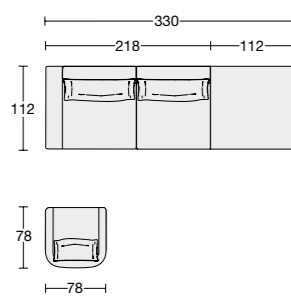

Composizione pagine 32/33

Divano Flap Large: rivestimento 1550/3/2 cat. EXTRA e piedini colore nero
Poltrona Plaza: struttura e piedini in cuoietto colore testa di moro, cuscini rivestimento 1520/90 cat. EXTRALUX

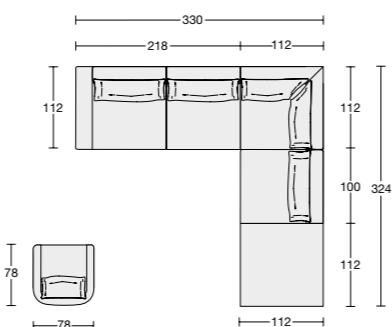

FLAP LARGE 699/700

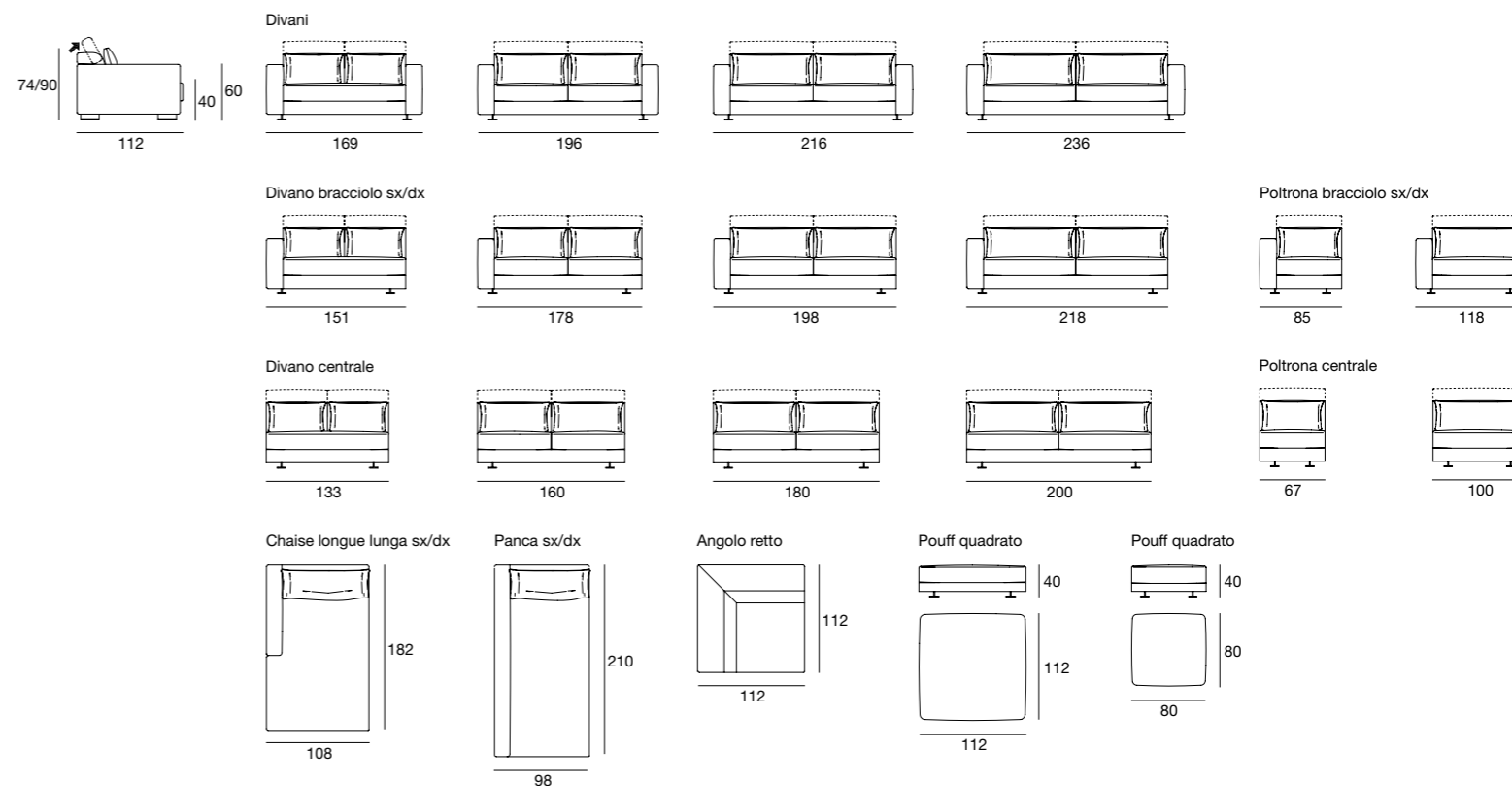

FLAP 701/702

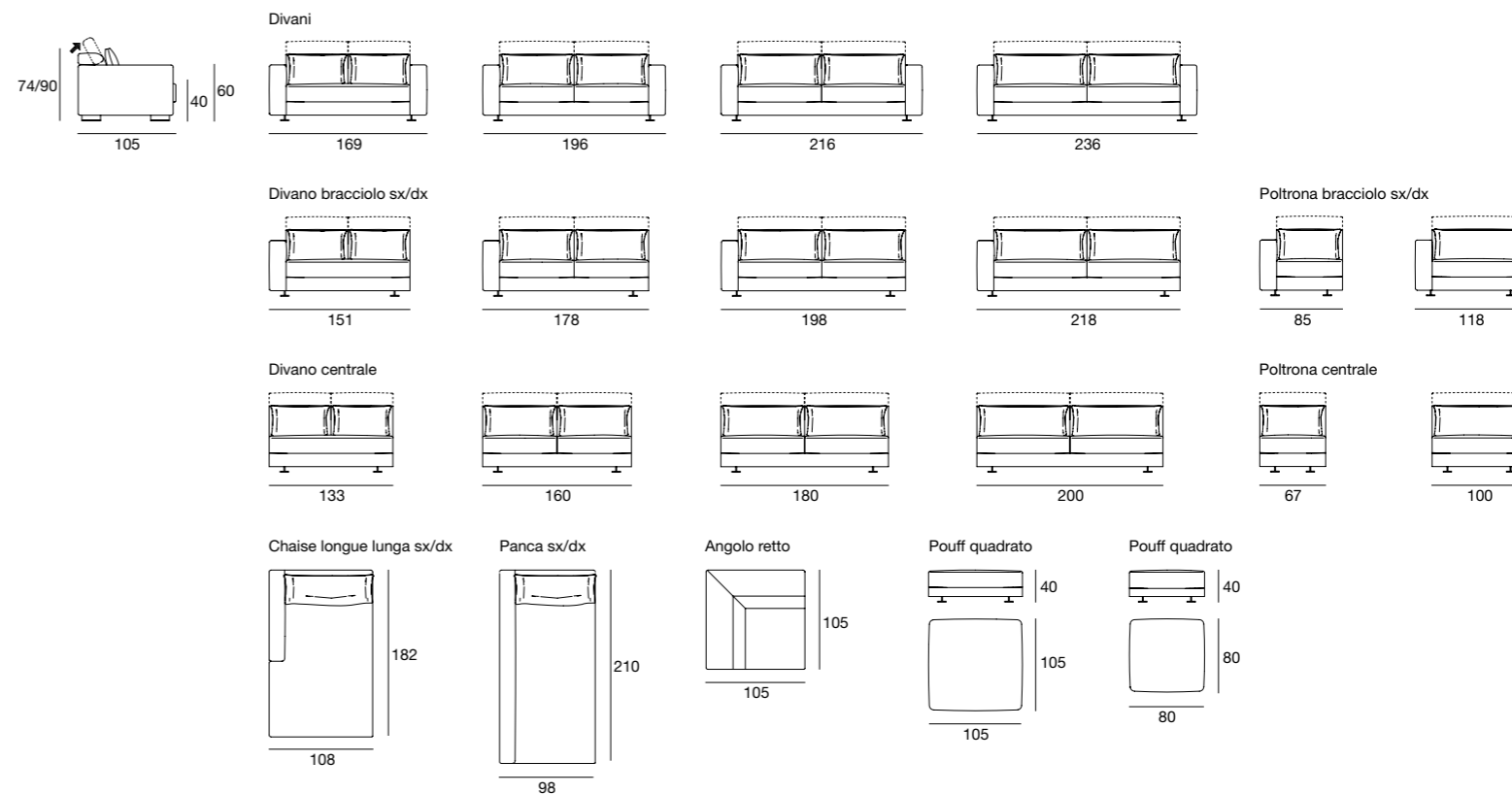

Variante Piedini



Piedino in alluminio verniciato brun sablé | Piedino in alluminio verniciato nero | Piedino in alluminio lucido | Piedino in alluminio satinato | Piedino in alluminio verniciato bianco

ROGER

design marconato&zappa

Caratteristiche: Il modello Roger si propone con una vasta gamma di elementi fissi o componibili. Dettagli di alta qualità sono la lavorazione con profilo del rivestimento in tessuto e il cuscinetto reggischiena dietro i cuscini schienale. Speciale rete ortopedica a doghe per la versione con comodo letto. Roger è completamente sfoderabile.

Struttura: 1_Structura in legno di abete. 2_Pannelli di legno multistrato.

3_Molleggio ottenuto con cinghie elastiche Intes Elabelt 790/4 larghezza 90 mm.

Imbottitura della struttura: 4_Poliuretano espanso a densità differenziate T30 N e T75. 5_Resinato accoppiato T1/ sc 200 gr.

Imbottitura dei cuscini versione piuma: 6_Cuscino poggiatesta in espanso densità T30. 7_Cuscino schienale in piuma d'oca ORO, con inserto in poliuretano espanso a densità differenziata SH 30 e T21 SS rivestito in pelleovo di cotone.

8_Cuscino sedile in piuma d'oca ORO, con inserto in poliuretano espanso a densità differenziata T35 SP e T30 SM rivestito in pelleovo di cotone.

Imbottitura dei cuscini versione poliuretano: 6_Cuscino poggiatesta in espanso densità T30. 7_Cuscino schienale in poliuretano espanso a densità differenziata SH 30 e T21 SS rivestito con fibra di Dacron 400 gr accoppiata con tela di cotone. 8_Cuscino sedile in poliuretano espanso a densità differenziata T35 Eucalipto e T30 SM rivestito con fibra di Dacron 400 gr accoppiata con tela di cotone.

Rivestimento: 9_Rivestimento in pelle o in tessuto completamente sfoderabile.

Finiture: 10_Piedino in alluminio disponibile nelle finiture: lucido, satinato e verniciato nei colori brun sablé, nero e bianco.

Characteristics: The Roger model has a broad line of fixed and modular elements. High quality details include processing with fabric covered cover edging and back support pad behind the back cushions. Special orthopaedic slats for comfort bed version. Roger has a completely removable cover.

Structure: 1_Fir wood frame. 2_Engineered wood panels. 3_Elastic belt suspension (Intes Elabelt 790/4 width 90 mm).

Structure padding: 4_Differentiated density polyurethane foam (T30 N and T75). 5_Coupled resin T1/ sc 200 gr.

Cushion padding goose down type: 6_Lower back cushions in density polyurethane foam T30. 7_Back cushions in ORO goose down, with differentiated density polyurethane foam (SH 30 and T21 SS) covered with fine muslin.

8_Seat cushions in ORO goose down, with differentiated density polyurethane foam (T35 SP and T30 SM) covered with fine muslin.

Cushion padding polyurethane type: 6_Lower back cushions in density polyurethane foam T30. 7_Back cushions in differentiated density polyurethane foam (SH 30 and T21 SS) covered with Dacron fibre (400 gr) coupled with cotton fabric.

8_Seat cushions in differentiated density polyurethane foam (T35 Eucalipto and T30 SM) covered with Dacron fibre (400 gr) coupled with cotton fabric.

Cover: 9 Completely removable leather or fabric cover.

Finishing: 10_Aluminium feet available in different finishes: polished, satin or painted in sandy brown, black and white.

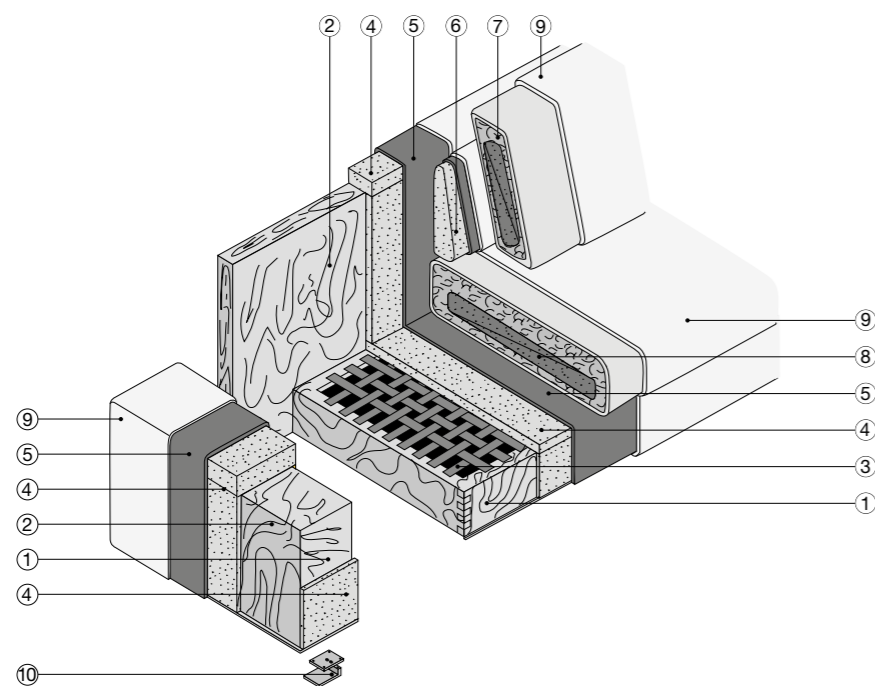

Composizione pagine 34/35 - 36/37

Divano Roger: rivestimento pelle Cristal 25 moka cat. ANILINA e piedini neri
Poltrona Rebecca: rivestimento 1480/73 cat. H piedini frassino tinto nero poro aperto
Tavolini Elliot: piano marmo Emperador e basamento frassino tinto nero poro aperto

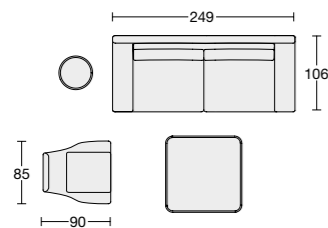

Composizione pagine 38/39

Divano Roger: rivestimento 1480/2 cat. H profilo in contrasto color ferro 46 e piedini brun sablé
Poltrona e pouff Elle: rivestimento 1520/89 cat. EXTRALUX basamento frassino tinto wengé
Tavolino Elliot: piano marmo Emperador e basamento frassino tinto nero poro aperto

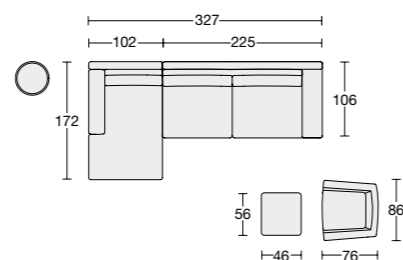

Composizione pagine 40/41

Divano Roger: rivestimento 1500/02 cat. EXTRA profili tono su tono e piedini alluminio satinato

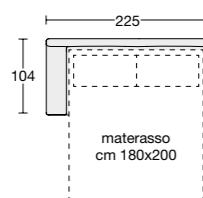

ROGER 693/694

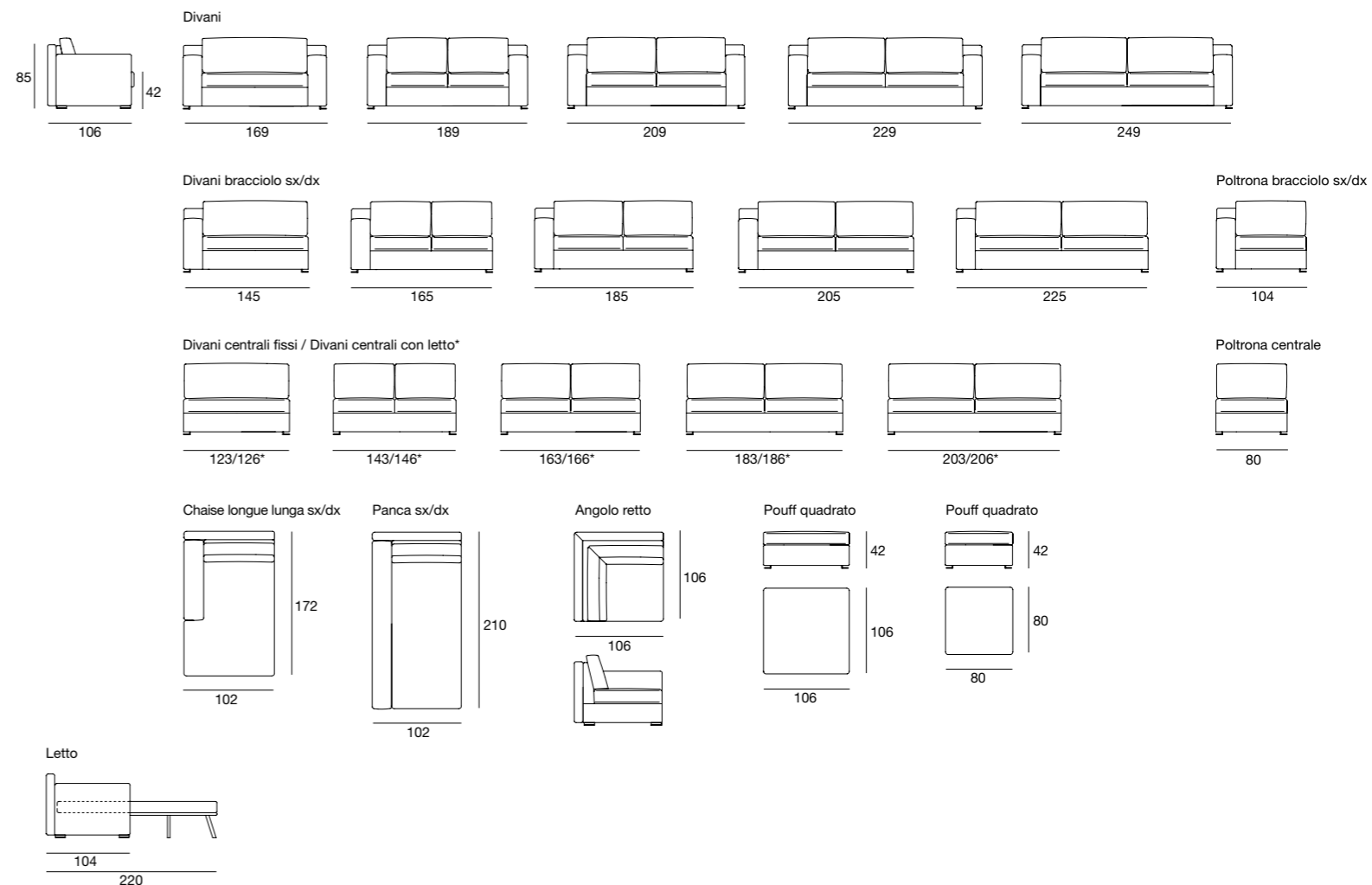

Nei divani con meccanismo letto la profondità sarà di cm 104 inclusi tutti gli elementi che formano la composizione. For sofas with bed mechanism, the depth is 104 cm including all composition elements.

Il letto è disponibile con rete ortopedica a doghe speciali in faggio e materasso in espanso speciale rivestito in spugna trapuntata 400 gr. The bed is available with orthopaedic base with special beech wood slats and mattress in special expanded covered with 400 gr quilted terry.

La rete da cm 122 si può inserire nei divani cm 126/145/169 (materasso cm 100 x 200 x 12h). The cm 122 base can be fitted in sofas cm 126/145/169 (mattress cm 100 x 200 x 12h).
La rete da cm 142 si può inserire nei divani cm 146/165/189 (materasso cm 120 x 200 x 12h). The cm 142 base can be fitted in sofas cm 146/165/189 (mattress cm 120 x 200 x 12h).
La rete da cm 162 si può inserire nei divani cm 166/185/209 (materasso cm 140 x 200 x 12h). The cm 162 base can be fitted in sofas cm 166/185/209 (mattress cm 140 x 200 x 12h).
La rete da cm 182 si può inserire nei divani cm 186/205/229 (materasso cm 160 x 200 x 12h). The cm 182 base can be fitted in sofas cm 186/205/229 (mattress cm 160 x 200 x 12h).
La rete da cm 202 si può inserire nei divani cm 206/225/249 (materasso cm 180 x 200 x 12h). The cm 202 base can be fitted in sofas cm 206/225/249 (mattress cm 180 x 200 x 12h).

Varianti colori profilo

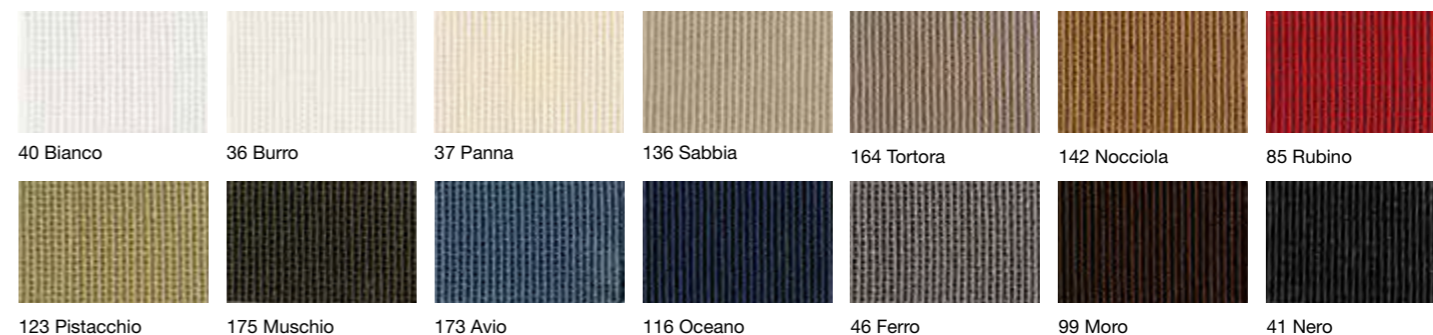

Variante Piedini



ANDY

design marconato&zappa

Caratteristiche: Andy propone un'ampia gamma di soluzioni compositive. L'elegante bombatura del bracciolo e la base con tubolare in alluminio esaltano una personalità decisa mentre i cuscini imbottiti, proposti sia in versione piuma che poliuretano, consentono un relax senza confronti. Completamente sfoderabile è disponibile anche con letto matrimoniale.

Struttura: 1_Structura in legno di abete. 2_Pannelli di legno compensato.

3_Molle ottenute con cinghie elastiche Intes Elsbelt 790/4 larghezza 90 mm.

Imbottitura della struttura: 4_Poliuretano espanso a densità differenziate T30 N e T75. 5_Resinato accoppiato T1/ sc 200 gr.

Imbottitura dei cuscini versione piuma: 6_Cuscino schienale in piuma d'oca ORO, con inserto in poliuretano espanso a densità differenziata T30 S e T21 SS rivestito in pelleo di cotone. 7_Cuscino sedile in piuma d'oca ORO, con inserto in poliuretano espanso a densità differenziata T35 SM e T30 S rivestito in pelleo di cotone.

Imbottitura dei cuscini versione poliuretano: 6_Cuscino schienale in poliuretano espanso a densità differenziata T30 S e T21 SS rivestito con fibra di Dacron accoppiata con tela di cotone. 7_Cuscino sedile in poliuretano espanso a densità differenziata T35 SM e T30 S rivestito con fibra di Dacron 400 gr accoppiata con tela di cotone.

Rivestimento: 8_Rivestimento in pelle o in tessuto completamente sfoderabile.

Finiture: 9_Tubolare in estruso di alluminio con elementi di giunzione in alluminio pressofuso disponibili nelle finiture: lucido, satinato e verniciato nei colori brun sablé, nero e bianco. Appoggio a terra con piedini tecnici arretrati.

Characteristics: Andy offers a wide range of compositions. The elegant rounding of the arms and tubular aluminium base are the distinctive marks of this straightforward model with padding either down or polyurethane foam that offers matchless comfort. With completely removable cover, it also comes with double bed.

Structure: 1_Fir wood frame. 2_Plywood panels. 3_Springing with elastic belts type Intes Elsbelt 790/4 width 90 mm.

Structure padding: 4_Foamed polyurethane at differentiated densities T30-N e T75. 5_Coupled resin T1/sc 200 gr.

Cushion padding goose down type: 6_Back cushions in ORO goose down, with insert in differentiated density polyurethane foam T30 S and T21 SS covered with fine muslin. 7_Seated cushions in ORO goose down, with insert in differentiated density polyurethane foam T35 SM and T30 S covered with fine muslin.

Cushion padding polyurethane type: 6_Back cushions in differentiated density polyurethane foam T30 S and T21 SS covered with Dacron fibre coupled with cotton fabric. 7_Seated cushions in differentiated density polyurethane foam T35 Sm and T30 S covered with Dacron fibre 400 gr coupled with cotton fabric.

Cover: Completely removable leather or fabric cover.

Finishing: 9_Extruded tubular aluminium frame with cast aluminium joints available in different finishes: polished, satin or painted in sandy brown, black and white. Stands on the floor with retracted techno feet.

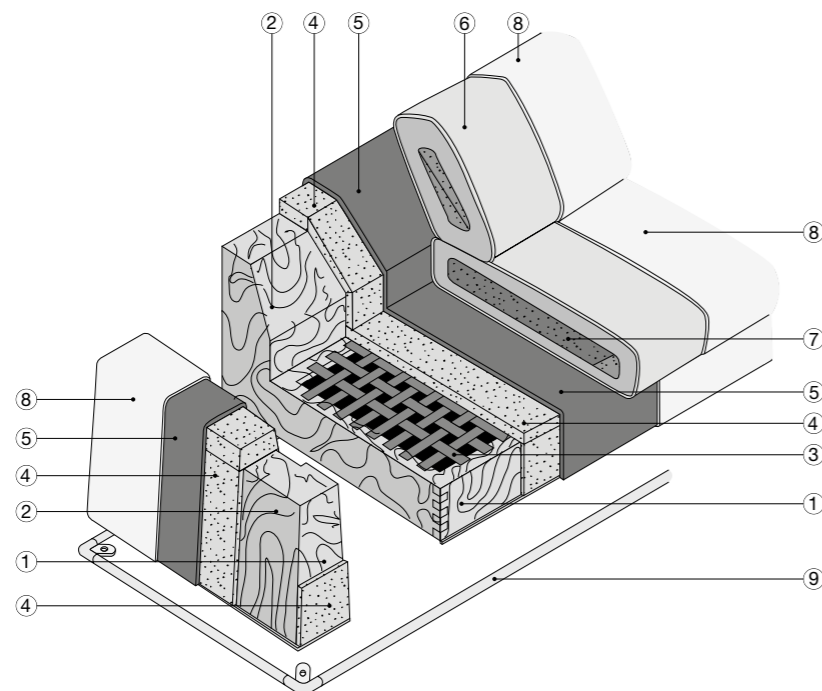

Composizione pagine 42/43

Divano Andy: rivestimento pelle Cristal 25 cat. anilina e basamento brun sablé



Composizione pagine 44/45

Divano Andy: rivestimento 1440/11 cat. EXTRA e basamento brun sablé
Poltrona Rebecca: rivestimento pelle Cristal 51 cat. anilina con basamento girevole brun sablé

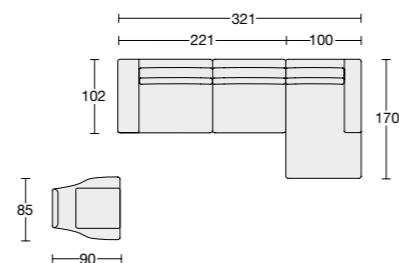

Composizione pagine 46/47

Divano Andy: rivestimento 1460/10 cat. H e basamento alluminio satinato
Pouf: rivestimento 1450/10 cat. EXTRA e basamento alluminio satinato

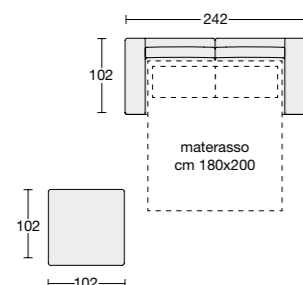

ANDY 688/689

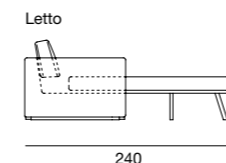
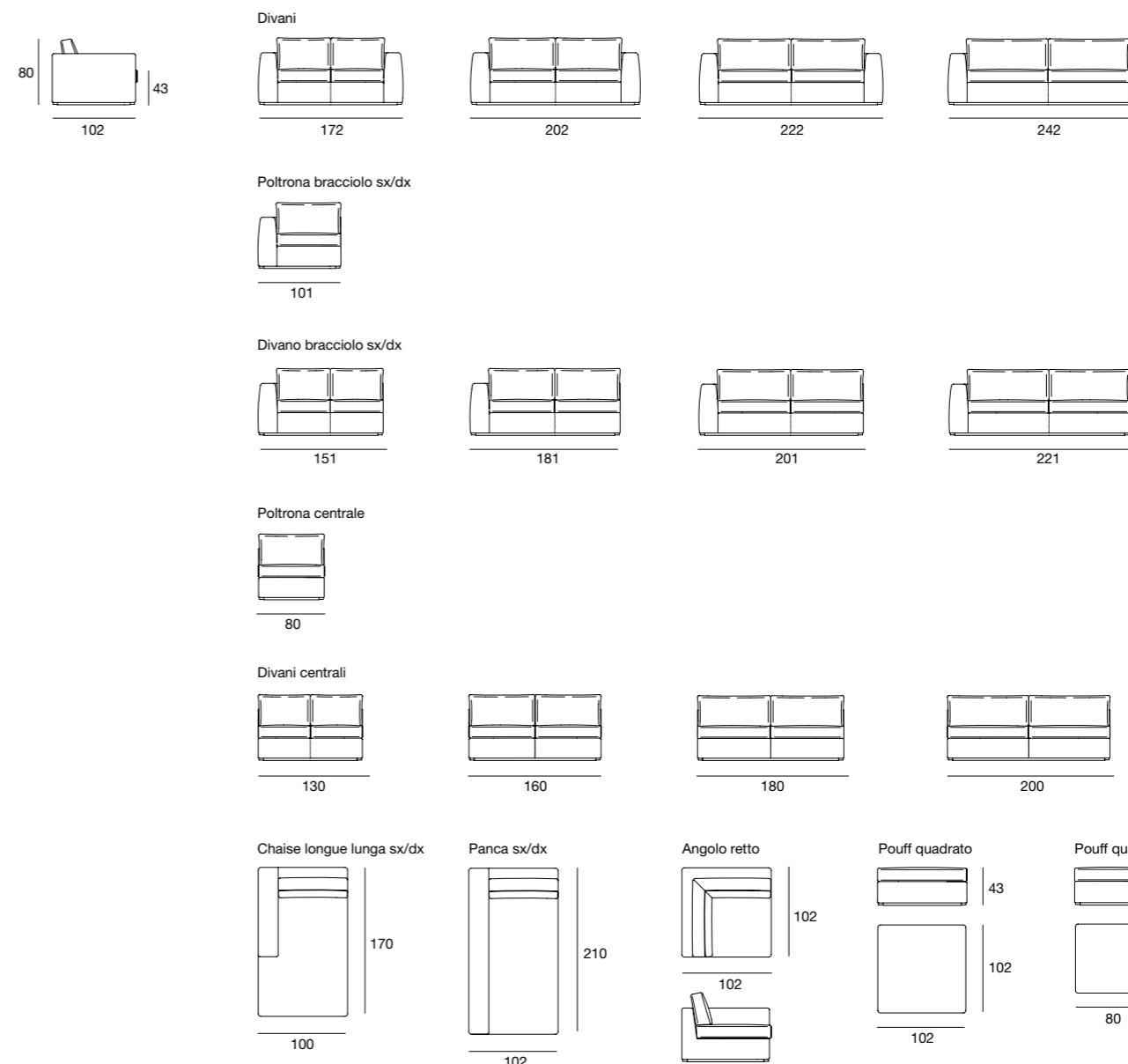

Il letto è disponibile con rete ortopedica a doghe in faggio o rete a maglia e materasso in espanso speciale rivestito in fodera di cotone trapuntato. The bed is available with orthopaedic base with beech wood slats or link mesh and mattress in special expanded covered in quilted cotton fabric.

La rete da cm 122 si può inserire nei divani cm 130/151/172 (mat. 105x180x8h.) The cm 122 base can be fitted in sofas cm 130/151/172 (mattress 105x180x8h.)

La rete da cm 152 si può inserire nei divani cm 160/181/202 (mat. 135x180x8h.) The cm 152 base can be fitted in sofas cm 160/181/202 (mattress 135x180x8h.)

La rete da cm 172 si può inserire nei divani cm 180/200/201/221/222/242 (mat. 155x180x8h.) The cm 172 base can be fitted in sofas cm 180/200/201/221/222/242 (mattress 155x180x8h.)

Varianti basamento



Basamento in tubolare alluminio lucido

Basamento in tubolare alluminio satinato

Basamento in tubolare alluminio verniciato brun sablé

Basamento in tubolare alluminio verniciato nero

Basamento in tubolare alluminio verniciato bianco

ELLIOT

design marconato&zappa

Caratteristiche: Una collezione preziosa, con straordinarie possibilità arredative. Colpisce il morbido segno dei rombi con al centro il tipico bottone della lavorazione capitonnè. Disponibile nella versione completamente imbottita o nella versione con basamento in legno di frassino in sei varianti di finitura. La progettazione ha considerato un valore importante la possibilità di un montaggio semplice, veloce e per un comodo trasporto.

Struttura: 1_Structura basamento in frassino. 2_Telaio metallo verniciato.

3_Structura in legno di abete. 4_Molleggio ottenuto con cinghie elastiche Intes Elsbelt larghezza 60mm. 5_Perni e viti per il montaggio.

Imbottitura della struttura: 6_Poliuretano espanso T35. 7_Poliuretano espanso T40.

Imbottitura dei cuscini: 8_Cuscino seduta in piuma d'oca ORO, con inserto in poliuretano espanso a densità differenziata T30 SP e T35 SM rivestito in pelleoivo di cotone.

Rivestimento: 9_Rivestimento in pelle o in tessuto.

Finiture basamento: 10_Basamento in legno di frassino naturale, tinto noce, tinto noce scuro, tinto wengé, in frassino laccato bianco o nero poro aperto oppure completamente rivestito. 11_Puntali ovali in alluminio lucido con feltrino.

Characteristics: A refined collection with extraordinary decorating potential.

The soft diamond shapes and central button of the capitonnè upholstery process catch the eye. Comes in two versions: fully upholstered or with ashwood base in six different finishes. The design offers the added value of quick, easy installation and convenient transport.

Structure: 1_Ashwood base frame. 2_Painted metal frame.

3_Fir wood frame. 4_Elastic belt suspension Intes Elsbelt width 60mm. 5_Pins and screws for installation.

Structure padding: 6_Polyurethane foam T35. 7_Polyurethane foam T40.

Cushion padding: 8_Seat cushions in ORO goose down, with insert in differentiated density polyurethane foam T30 SP and T35 SM covered with fine muslin.

Cover: 9_Leather or fabric cover.

Finishing base: 10_Base in natural ashwood stained walnut, dark walnut, wengé or in ashwood with white or black open-pore lacquer or completely covered. Oval, polished aluminium foot caps with felt pads.

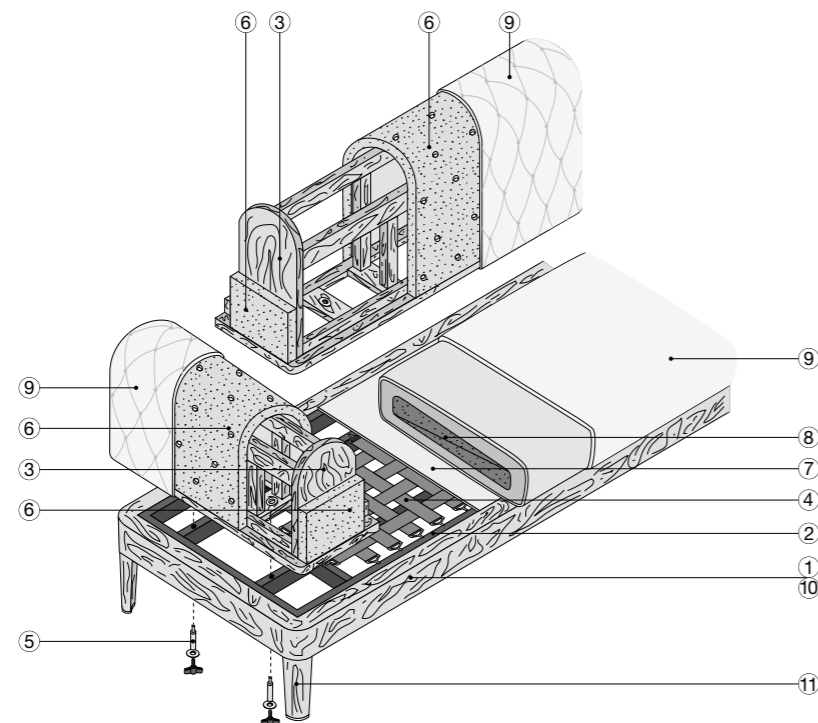

Composizione pagine 48/49

Divano Elliot tutto imbottito: rivestimento velluto 1470/17 cat. EXTRALUX
Poltrona tutta imbottita: rivestimento velluto 1470/17 cat. EXTRALUX

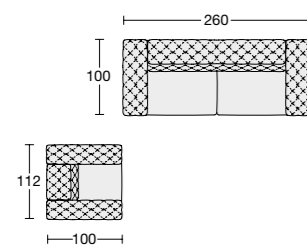

Composizione pagine 50/51 - 52/53

Divano Elliot tutto imbottito: rivestimento pelle Diamante 7851 cat. ANILINA
Poltroncine: rivestimento velluto 1470/2012 cat. EXTRALUX e basamento frassino tinto wengé
Pouff tutto imbottito: rivestimento pelle Diamante 7851 cat. ANILINA

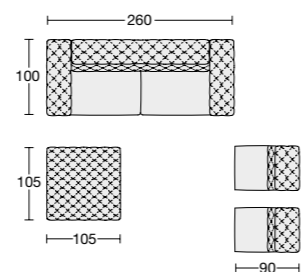

Composizione pagine 54/55

Divano Elliot: rivestimento velluto 1470/2003 cat. EXTRALUX e basamento frassino tinto nero poro aperto
Chaise longue dx tutta imbottita: rivestimento velluto 1470/28 cat. EXTRALUX

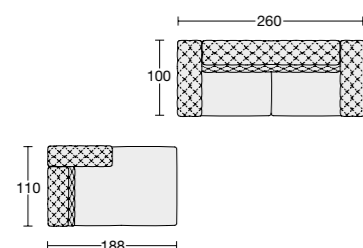

ELLIOT 692 BASAMENTO IMBOTTITO

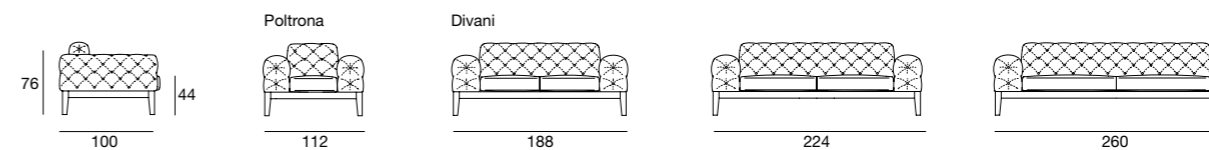

Chaise longue lunga sx/dx

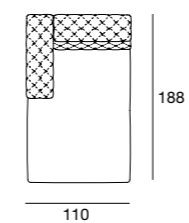

Pouff quadrato

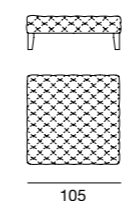

Pouff rettangolare

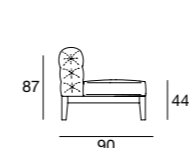
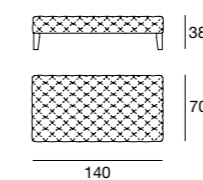

Poltroncina



ELLIOT 691 BASAMENTO LEGNO

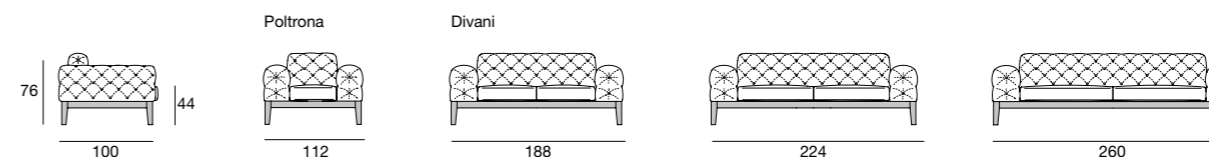

Chaise longue lunga sx/dx

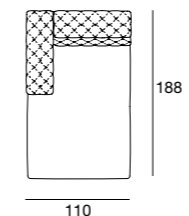

Poltroncina

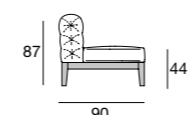

Montaggio semplice e veloce



Varianti basamento



PREMIÈRE

design marconato&zappa

Caratteristiche: Una componibilità generosa grazie alla vasta gamma di elementi fissi e aggregabili. Première è sicuramente un divano dalla comodità superiore grazie alla possibilità di alzare e posizionare la parte alta dello schienale ottenendo un confortevole poggia-testa. Morbidi cuscini orizzontali poggia-reni completano la speciale dotazione di Première. Particolare ed esclusivo è il design del bracciolo.

A richiesta, cuscinatura sedute e poggia-reni possono essere realizzate in piuma d'oca con inserto in poliuretano. Première è completamente sfoderabile.

Struttura: 1_Structura in legno di abete. 2_Pannelli di legno compensato. 3_Pannelli di legno multistrati. 4_Molle ottenute con cinghie elastiche Elasmat 790/4 larghezza 90 mm.

Imbottitura della struttura: 5_Poliuretano espanso a densità differenziata TL25 - T40P - SR75. 6_Resinato 100 gr. accoppiato con vellutino.

Imbottitura dei cuscini: 7_Cuscini sedile in poliuretano espanso a densità differenziata WLD35 - OS30FM. 8_Termolegato 400 gr. con tela di cotone.

9_Cuscini schienali in poliuretano espanso a densità differenziata PF25SM - OS30FM - PF30M - T40F - MTP95. 10_Termolegato 300 gr. con tela di cotone. 11_Cuscinetto poggia-rieni in poliuretano espanso OS30FM.

12_Termolegato 400 gr. con tela di cotone.

Rivestimento: 13_Rivestimento in pelle o in tessuto completamente sfoderabile.

Finiture: 14_Piedini in faggio tinto.

Characteristics: Generous modular design thanks to the extensive range of fixed and compositional elements. The comfort of the Première sofa is without a doubt superior because it is possible to raise and position the top part of the backrest to obtain a relaxing headrest. Soft, horizontal lower back cushions complete the special fittings on Première. The armrest design is unusual and exclusive. On request, the seat and backrest cushions can be down-filled with polyurethane inner foam core. Première has fully removable covers.

Structure: 1_Pinewood frame. 2_Plywood panels. 3_Multilayer panels.

4_Suspension obtained from 90 mm wide, Elasmat 790/4 elastic belts.

Structure padding: 5_Differentiated density expanded polyurethane TL25 - T40P - SR75. 6_Resin 100 gr. coupled with velveteen.

Cushions padding: 7_Seat cushions in differentiated density expanded polyurethane: WLD35 - OS30FM. 8_Heat bonded with 400 gr. cotton cover.

9_Backrest cushions in differentiated density expanded polyurethane: PF25SM - OS30FM - PF30M - T40F - MTP95. 10_Heat bonded with 300 gr. cotton cover. 11_Loinrest in differentiated density expanded polyurethane OS30FM.

12_Heat bonded with 400 gr. cotton cover.

Cover: 13_Completely removable leather or fabric cover.

Finishing: 14_Feet in tinted beech-wood.

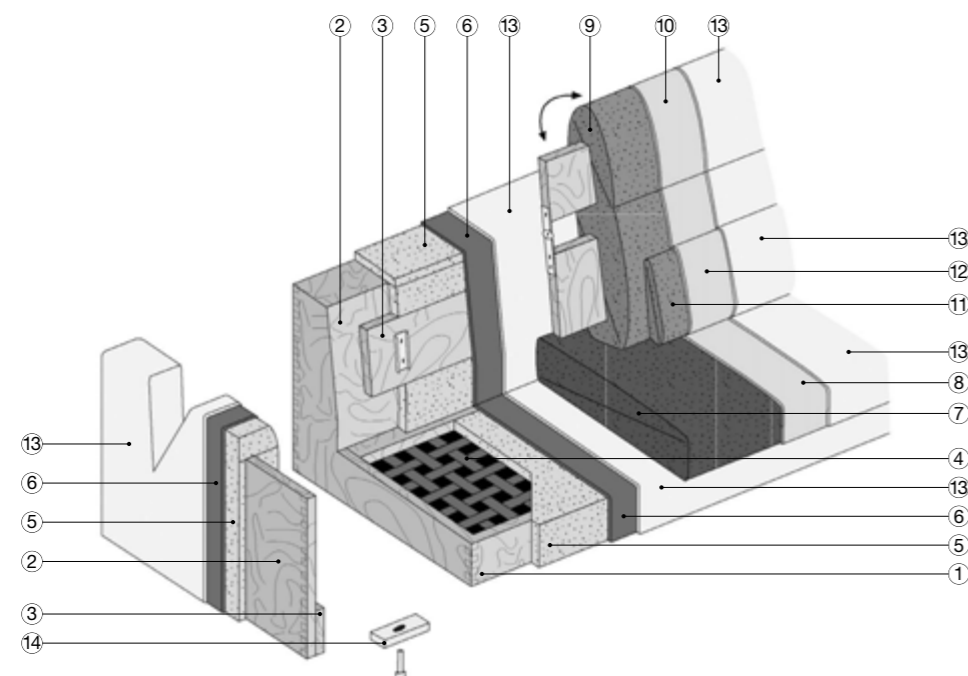
**Composizione pagine 56/57**

Divano Première: rivestimento pelle Nabuk 17

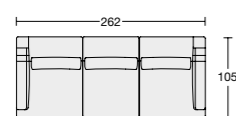
**Composizione pagine 58/59**

Divano Première: rivestimento 1310/05 cat. H
Pouf: rivestimento 1310/05 cat. H

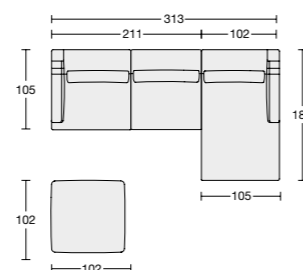
**Composizione pagine 60/61**

Divano Première: rivestimento 1300/11 cat. H
Poltrone Moon: rivestimento 1310/7 cat. H e basamento tinta wengè

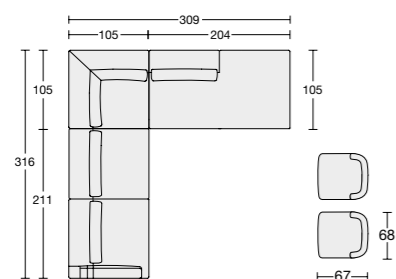

PREMIÈRE 676

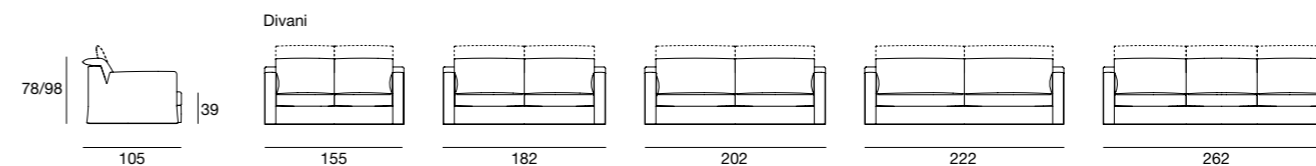

Poltrone bracciolo sx/dx

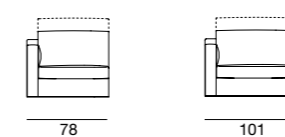

Divani bracciolo sx/dx

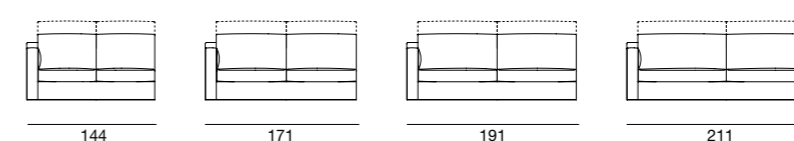

Poltrone centrali

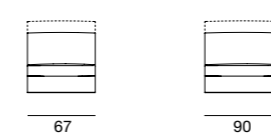

Divani centrali

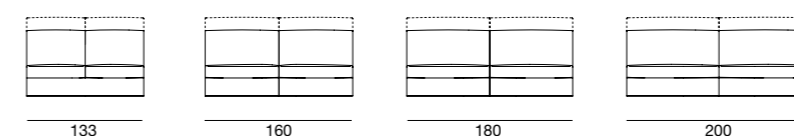

Penisola sx/dx

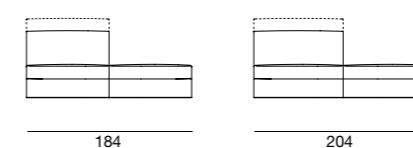

Chaise longue lunga sx/dx

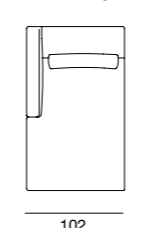

Angolo retto

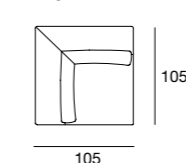

Pouff quadrato

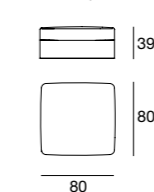

Pouff quadrato

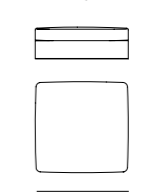

HAVEN

design marconato&zappa

Caratteristiche: Haven è un sistema di sedute vario e completo di ampie soluzioni compositive. Il design rassicurante di questo modello consente il suo inserimento in ogni architettura domestica. Caratteristica principale è una seduta dallo schienale alto che lo rende un prodotto di grande comodità. Originale design dei piedini in metallo verniciato proposti nelle finiture brun sablé, nero, bianco e grigio. Haven è completamente sfoderabile.

Struttura: 1_Structura in legno di abete. 2_Pannelli di legno compensato.

3_Molle ottenute con cinghie elastiche Intes Elabelt 790/S larghezza 90 mm.

4_Guide per montaggio divano.

Imbottitura della struttura: 5_Poliuretano espanso a densità differenziate Olmo Polilatex T50-D, Olmo Polilatex T40-P e Olmo Polilatex T25.

6_Vellutino accoppiato 350 gr. con cotone accoppiato 3 mm.

Imbottitura dei cuscini: 7_Cuscini schienale in poliuretano espanso a densità differenziate Olmo PF 21/SM, Olmo PF 25/SM, Olmo PF 30/M e Olmo WLD 25/S.

8_Cuscini seduta con inserto in poliuretano espanso a densità differenziata Ecoelast 40, Olmo T40RC e Olmo Viscoelastico 40.

9_Termolegato con fodera di cotone 400 gr.

Rivestimento: 10_Rivestimento in pelle o in tessuto completamente sfoderabile.

Finiture: 11_Piedini in metallo verniciato colore bianco, brun sablé, grigio e nero.

Characteristics: Haven is a varied, complete seating system that can be used for many different compositions. Its reassuring design makes it suitable for any domestic architecture. Its key feature is the high backrest seat, offering great comfort. The original design of the painted metal feet comes in the following finishes: sandy brown, black, white and grey. Haven covers are fully removable.

Structure: 1_Fir wood frame. 2_Plywood panels. 3_Springing with elastic belts type Intes Elabelt 790/S width 90 mm. 4_Sofa assembly guide-rails.

Structure padding: 5_Differentiated density polyurethane foam: Olmo Polilatex T50-D, Olmo Polilatex T40-P and Olmo Polilatex T25.

6_Velveteeen coupled 350 gr. with cotton fabric 3 mm.

Cushion padding: 7_Backrest cushions in differentiated density polyurethane foam: Olmo PF 21/SM, Olmo PF 25/SM, Olmo PF 30/M and Olmo WLD 25/S. 8_Seat cushions with insert in differentiated density polyurethane foam: Ecoelast 40, Olmo T40RC and Olmo Viscoelastic 40.

9_Heat-bonded with cotton lining 400 gr.

Cover: 10_Fully removable leather or fabric cover.

Finishing: 11_Painted metal feet in the following finishes: white, sandy brown, grey and black.

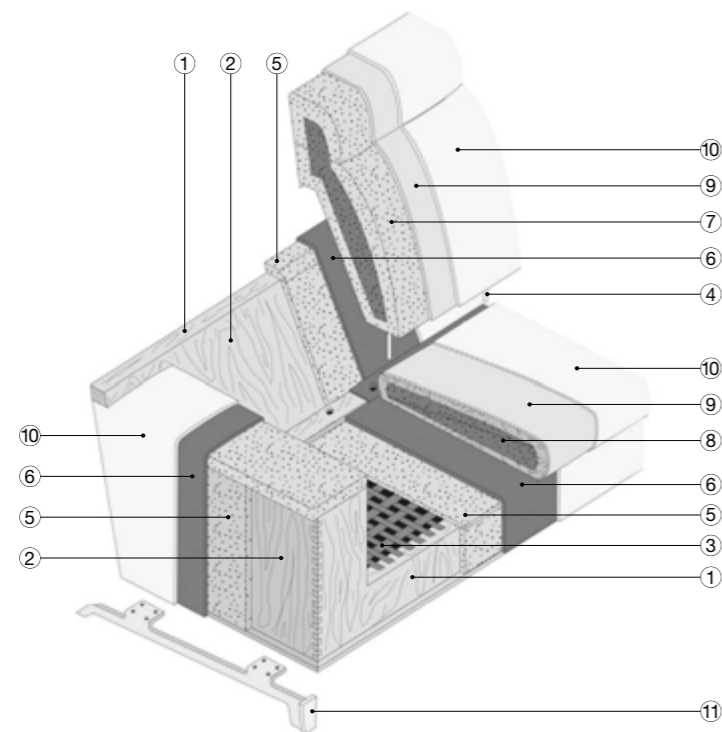

Composizione pagine 62/63

Divano Haven: rivestimento pelle Cristal 41 cat. anilina e piedini verniciati brun sablé
Poltrona Glee: rivestimento 1420/01-1 cat. EXTRA e piedini verniciati brun sablé

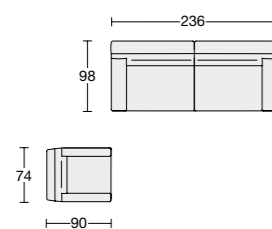

Composizione pagine 64/65

Divano Haven: rivestimento 1430/29 cat. H e piedini verniciati neri
Pouf: rivestimento 1430/29 cat. H e piedini verniciati neri

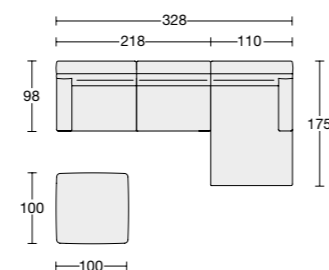

Composizione pagine 66/67

Divano Haven: rivestimento 1540/01 cat. G e piedini verniciati brun sablé
Poltrone Moon: rivestimento 1470/2003 cat. EXTRALUX e basamento tinta wengè

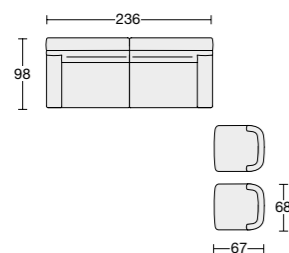

HAVEN 685



Varianti piedini



Piedino in metallo verniciato brun sablé

Piedino in metallo verniciato nero

Piedino in metallo verniciato bianco

Piedino in metallo verniciato grigio

TAILOR

design marconato&zappa

Caratteristiche: Tailor è un sistema di sedute con una versatilità compositiva ampia e completa. Il design è decisamente contemporaneo: spicca lo schienale basso con morbidi cuscini e piedini in metallo verniciati nelle finiture brun sablè, nero, bianco e grigio. Tailor è un sistema completamente sfoderabile, anche nella versione pelle.

Struttura: 1_Structura in legno di abete. 2_Pannelli di legno compensato.

3_Molle ottenute con cinghie elastiche Intes Elabelt 790/S larghezza 90 mm.

Imbottitura della struttura: 4_Poliuretano espanso a densità differenziate Olmo Polilatex T50-D, Olmo Polilatex T40-P e Olmo Polilatex T25.

5_Vellutino accoppiato 350 gr. con cotone accoppiato 3 mm.

Imbottitura Dei Cuscini: 6_Cuscini schienale in poliuretano espanso a densità differenziate Olmo PF 21/SM, Olmo PF 25/SM, Olmo PF 30/M e Olmo WLD 25/S. 7_Cuscini seduta con inserto in poliuretano espanso a densità differenziata Ecoelast 40, Olmo T40RC e Olmo Viscoelastico 40.

8_Termolegato con fodera di cotone 400 gr.

Rivestimento: 9_Rivestimento in pelle o in tessuto completamente sfoderabile.

Finiture: 10_Piedini in metallo verniciato colore bianco, brun sablè, grigio e nero.

Characteristics: The extremely versatile Tailor seating system can be used in a wide range of compositions. The unquestionably contemporary design features a low backrest with soft cushions and painted metal feet in the following finishes: sandy brown, black, white and grey. The Tailor system has fully removable covers, including for its leather version.

Structure: 1_Fir wood frame. 2_Plywood panels. 3_Springing with elastic belts type Intes Elabelt 790/S width 90 mm.

Structure padding: 4_Differentiated density polyurethane foam: Olmo Polilatex T50-D, Olmo Polilatex T40-P and Olmo Polilatex T25.

5_Velveten coupled 350 gr. with cotton fabric 3 mm.

Cushion padding: 6_Backrest cushions in differentiated density polyurethane foam: Olmo PF 21/SM, Olmo PF 25/SM, Olmo PF 30/M and Olmo WLD 25/S. 7_Seat cushions with insert in differentiated density polyurethane foam: Ecoelast 40, Olmo T40RC and Olmo Viscoelastic 40.

8_Heat-bonded with cotton lining 400 gr.

Cover: 9_Fully removable leather or fabric cover.

Finishing: 10_Painted metal feet in the following finishes: white, sandy brown, grey and black.

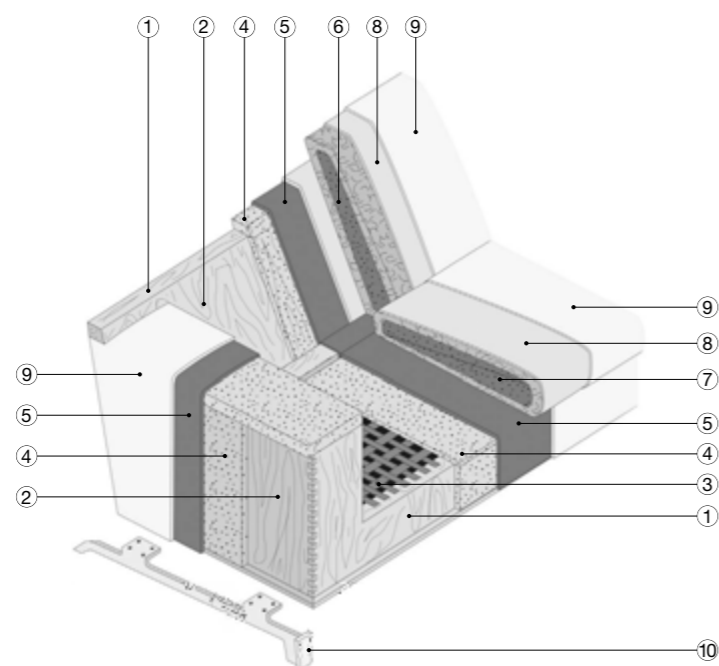

Composizione pagine 68/69

Divano Tailor: rivestimento 1410/24-5 cat. H e piedini verniciati neri

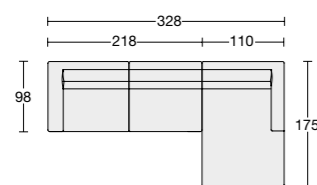

Composizione pagine 70/71

Divano Tailor: rivestimento pelle Cristal 47 cat. Anilina e piedini verniciati brun sablè

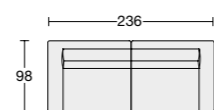

Composizione pagine 72/73

Divano Tailor: rivestimento 1390/01 cat. G e piedini verniciati brun sablè

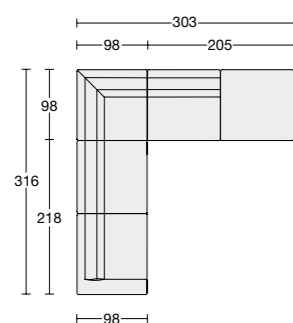

TAILOR 684

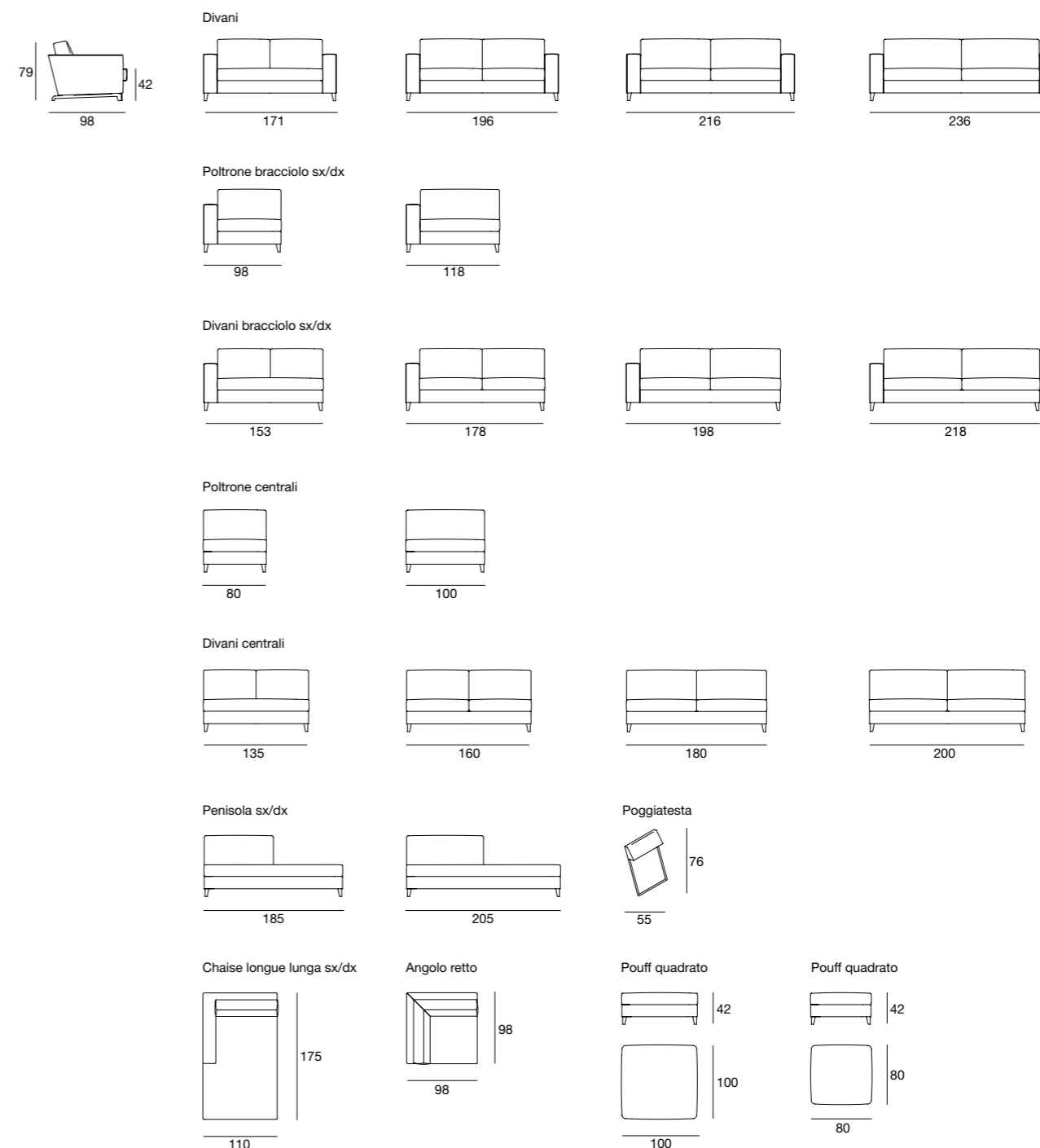

Varianti piedini



Piedino in metallo verniciato brun sablè

Piedino in metallo verniciato nero

Piedino in metallo verniciato bianco

Piedino in metallo verniciato grigio

PASSION

esetidesign

Caratteristiche: Passion è un sistema di sedute vario e con ampie soluzioni compositive. Il design sobrio e rassicurante di questo modello permette l'inserimento in ogni situazione arredativa. Caratteristica principale è la possibilità di avere un vero e comodo letto con rete ortopedica. Passion si presenta con due varianti di cuscinatura: la prima è in piuma con inserto in poliuretano espanso, la seconda è in poliuretano speciale. Passion è completamente sfoderabile.

Struttura: 1_Structura in legno di abete. 2_Pannelli di legno compensato.

3_Molle ottenute con cinghie elastiche Intes Elabelt 790/S larghezza 90 mm.

Imbottitura della struttura: 4_Poliuretano espanso a densità differenziate Olmo POLILATEX 65 HD, Olmo HIGH COMFORT PF 21 SM e Olmo POLILATEX T 40 P.

5_Vellutino accoppiato TL 200 gr. e TL 100 gr. trapuntato rombato grigio.

Imbottitura dei cuscini versione piuma: 6_Cuscino schienale in piuma, con inserto in poliuretano espanso a densità differenziata Olmo HIGH COMFORT PF 21 SM e Olmo D/25 SM. Rivestito con fodera di cotone. 7_Cuscino sedile in piuma, con inserto in poliuretano espanso a densità differenziata Olmo HIGH COMFORT PF 35 e Olmo POLILATEX T 40/P e Olmo B.S PF 35 FR. Rivestito con fodera di cotone.

Imbottitura dei cuscini versione poliuretano: 6_Cuscino schienale in poliuretano espanso a densità differenziata Olmo D/25SM e Olmo HIGH COMFORT PF 21 SM. Rivestito con fibra di Dacron accoppiata con cotone 400 gr.

7_Cuscino sedile in poliuretano espanso a densità differenziata Olmo HIGH COMFORT PF 35 e Olmo POLILATEX T 40/P e Olmo B.S PF 35 FR. Rivestito con fibra di Dacron accoppiata con cotone 400 gr.

Rivestimento: 8_Rivestimento in pelle o in tessuto completamente sfoderabile.

Finiture: 9_Piedini in legno di faggio tinto.

Characteristics: Passion is a varied seating system with diverse compositional solutions. The sober and reassuring design of this model allows its inclusion in any furnishing situation. The main feature is its ability to offer a real comfortable bed with an orthopedic base. Passion is presented with two cushions variants: The first is in feathers with a polyurethane foam insert. The second is in special polyurethane foam. Passion has completely removable upholstery.

Structure: 1_Pinewood frame. 2_Pinewood panels.

3_Springing with elastic belts type Intes Elabelt 790/S width 90 mm.

Structure padding: 4_Foamed polyurethane at differentiated densities Olmo POLILATEX 65 HD, Olmo HIGH COMFORT PF 21 SM and Olmo POLILATEX T 40 P.

5_Velveteeen coupled TL 200 gr. and TL 100 gr. grey quilted rumber.

Cushions padding feather type: 6_Backrest in feather with foamed polyurethane insert at differentiated densities Olmo HIGH COMFORT PF 21 SM and Olmo D/25 SM. Covered with cotton fabric. 7_Seat cushion in feather with foamed polyurethane insert at differentiated densities Olmo HIGH COMFORT PF 35, Olmo POLILATEX T 40/P and Olmo B.S PF 35 FR. Covered with cotton fabric.

Cushion padding polyurethane type: 6_Backrest cushion in foamed polyurethane at various densities Olmo D/25SM and Olmo HIGH COMFORT PF 21 SM. Covered with Dacron fibre coupled with cotton 400 gr. 7_Seat cushion in foamed polyurethane at differentiated densities Olmo HIGH COMFORT PF 35, Olmo POLILATEX T 40/P and Olmo B.S PF 35 FR. Covered with Dacron fibre coupled with cotton 400 gr.

Cover: 8 Completely removable leather or fabric cover.

Finishing: 9_Feet in tinted beech-wood.

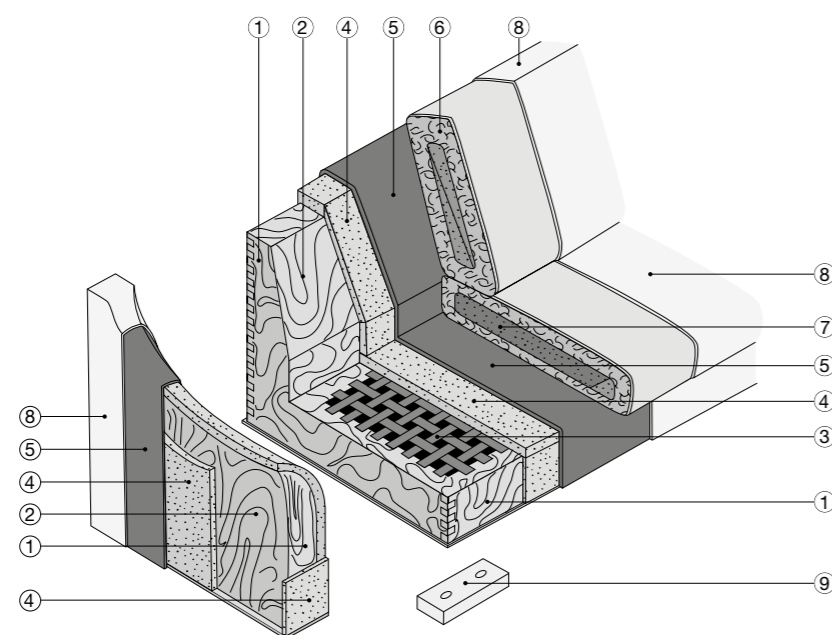

Composizione pagine 74/75

Divano Passion: rivestimento 1540/13 cat. G



Composizione pagine 76/77

Divano Passion: rivestimento pelle Cristal 51 cat. Anilina piedini wengè
Poltrona Passion: rivestimento 1550/3-2 cat. EXTRA

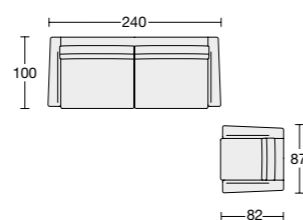

Composizione pagine 78/79

Divani Passion: rivestimento 1540-11 cat. G

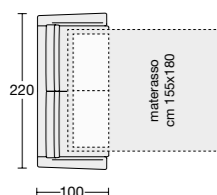
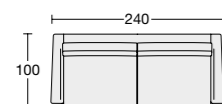

PASSION 680/681

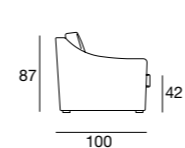

Divani

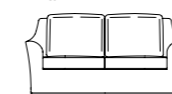

170



200

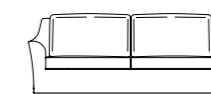

220

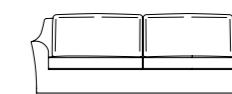

240

Poltrone bracciolo sx/dx



100



120

Divani bracciolo sx/dx

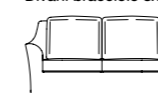

150

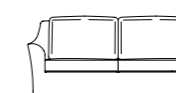

180

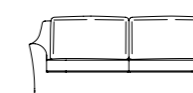

200

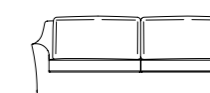

220

Poltrone centrali



80



100

Divani centrali



130

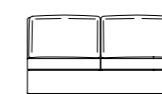

160

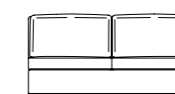

180

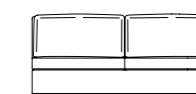

200

Chaise longue lunga sx/dx

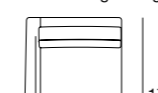

105

Angolo retto



87

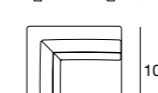

100

Pouff quadrato

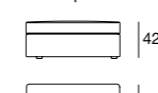

42

Pouff quadrato

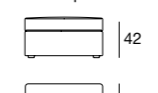

42

80

Poggiatesta

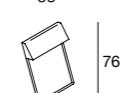

55

Cuscino



50

Poltrona

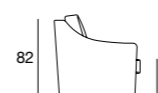

82



87

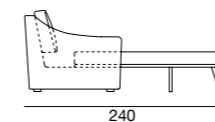

240

Il letto disponibile con rete ortopedica a doghe in faggio o rete a maglia e materasso in espanso speciale rivestito in fodera di cotone trapuntato. The bed is available with orthopaedic base with beech wood slats or link mesh and mattress in special expanded covered in cotton fabric.

La rete da cm 122 si può inserire nei divani cm 130/150/170 (mat. 105x180x8 h.) The cm 122 base can be fitted in sofas cm 130/150/170 (mattress 105x180x8 h.)

La rete da cm 152 si può inserire nei divani cm 160/180/200 (mat. 135x180x8 h.) The cm 152 base can be fitted in sofas cm 160/180/200 (mattress 135x180x8 h.)

La rete da cm 172 si può inserire nei divani cm 180/200/220/240 (mat. 155x180x8 h.) The cm 172 base can be fitted in sofas cm 180/200/220/240 (mattress 155x180x8 h.)

Varianti piedini



Piedino faggio tinto noce

Piedino faggio tinto wengè

LIGHT
design marconato&zappa

Caratteristiche: Straordinaria componibilità per un divano che diventa protagonista della casa contemporanea. Un design leggero che esprime un carattere forte ma accogliente grazie al bracciolo che si accorda sia con i generosi cuscini di schienale, sia con i piedini cilindrici in alluminio lucido o in faggio tinto in vari colori. Light è proposto in morbida piuma d'oca con inserto in poliuretano oppure in poliuretano espanso speciale, ed è completamente sfoderabile.

Struttura: **1** _Struttura in legno massello di abete. **2** _Pannelli di legno compensato. **3** _Pannelli di legno multistrati. **4** _Molleghio ottenuto con cinghie elastiche Intes Elabelt 790/4 larghezza 90 mm.

Imbottitura della struttura: **5** _Poliuretano espanso a densità differenziata T25 - PF30 - T40P - SR75. **6** _Vellutino accoppiato con espanso mm 10 TL/SC 200 gr. **7** _Accoppiato tessuto di cotone 100 gr. con vellutino.

Imbottitura dei cuscini versione piuma: **8** _Cuscini schienali in piuma d'oca bianca etichetta standard Assopioma, con inserto in poliuretano espanso a densità differenziata PF21SM - PF25SM - T40. **9** _Cuscini sedili in piuma d'oca bianca etichetta standard Assopioma, con inserto in poliuretano espanso a densità differenziata OS30FM - WLD35 - T40RC.

Imbottitura dei cuscini versione poliuretano: **8** _Cuscini schienali in poliuretano espanso a densità differenziata PF21SM - PF25SM + termolegato 400 gr. con fodera di cotone. **9** _Cuscini sedili in poliuretano espanso a densità differenziata EM40 - OS30FM + termolegato 400 gr. con fodera di cotone.

Rivestimento: **10** _Rivestimento in pelle o in tessuto completamente sfoderabile.

Finiture: **11** _Piedini in alluminio lucido oppure faggio naturale sbiancato o tinto: wengè, noce, noce scuro, ciliegio.

Characteristics: Particularly modular sofa that immediately takes centre stage in the contemporary home. A light design that expresses a strong, welcoming character thanks to the armrest that is a perfect match for the cushions forming the backrest in addition to the cylindrical feet in polished aluminium or different coloured beech. Light is a soft, down-filled sofa with polyurethane or special polyurethane inner foam core and has fully removable covers.

Structure: **1** _Pinewood frame. **2** _Plywood panels. **3** _Multilayer panels. **4** _Suspension obtained from 90 mm wide, Intes Elabelt 790/4 elastic belts.

Structure padding: **5** _Differentiated density expanded polyurethane T25 - PF30 - T40P - SR75. **6** _Velveteen coupled with foamed polyurethane mm 10 TL/SC 200 gr. **7** _Coupled cotton fabric 100 gr. with velveteen.

Cushions padding goose down type: **8** _Backrest cushions in white goose down Assopioma standard label with foamed polyurethane insert at differentiated densities PF21SM - PF25SM - T40. **9** _Seat cushions in white goose down Assopioma standard label with foamed polyurethane insert at differentiated densities OS30FM - WLD35 - T40RC.

Cushions padding polyurethane type: **8** _Backrest cushions in differentiated density expanded polyurethane PF21SM - PF25SM + heat bonded with 400 gr. cotton cover. **9** _Seat cushions in differentiated density expanded polyurethane EM40 - OS30FM + heat bonded with 400 gr. cotton cover.

Cover: **10** _Completely removable leather or fabric cover.

Finishing: **11** _Polished aluminium feet or beech-wood: natural bleached or tinted wengè, walnut, dark walnut, cherry.

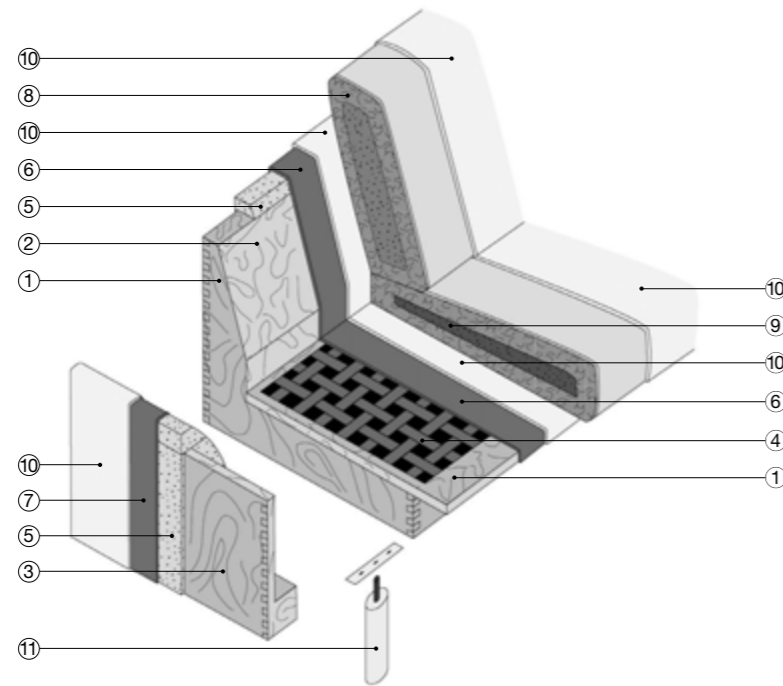

Composizione pagine 80/81

Divano Light: rivestimento 1310/01 cat. H piedini alluminio lucido
Pouff: rivestimento 1310/01 cat. H

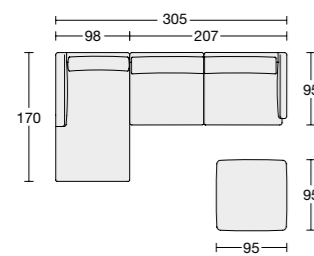

Composizione pagine 82/83

Divano Light: rivestimento 1300/01-4 cat. H piedini alluminio lucido
Poltrone Light: rivestimento 1300/01-3 cat. H piedini alluminio lucido

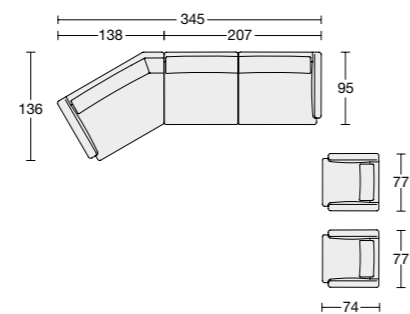

Composizione pagine 84/85

Divano Light: rivestimento pelle Diamante 816 cat. ANILINA piedini alluminio lucido

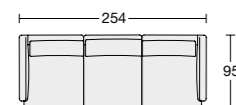

LIGHT 674/675

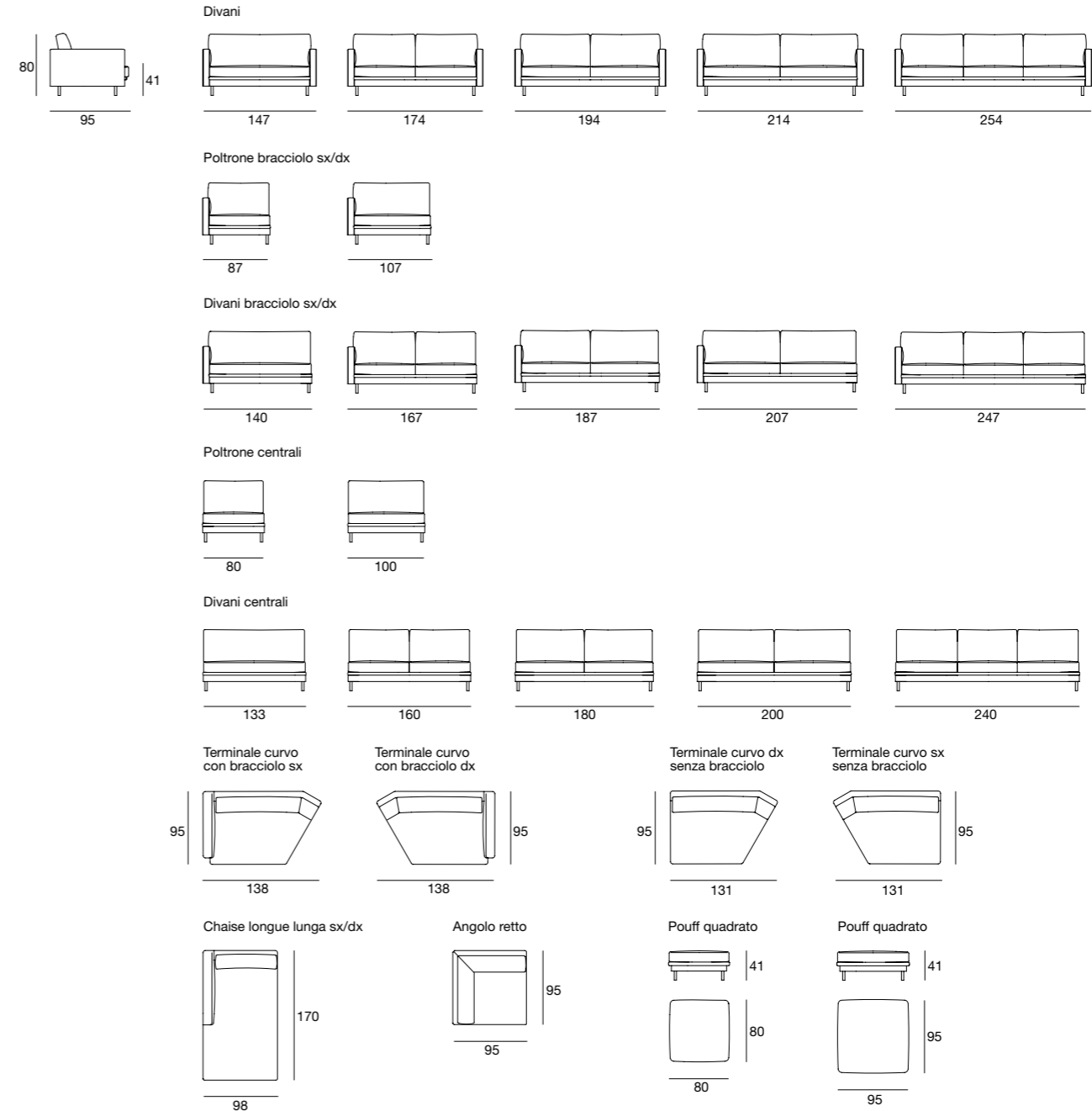

INGOMBRO TERMINALE CURVO

Terminale curvo con bracciolo da cm 138
Divano laterale di cm 140/167/187/207/247

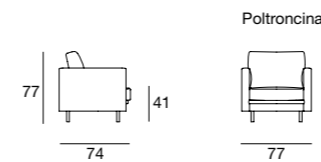
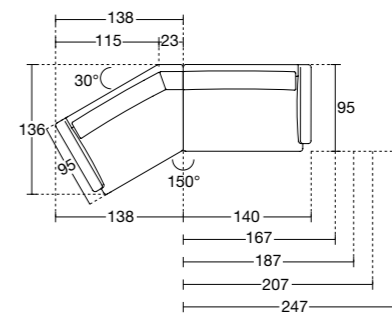

Variante Piedini



Piedino in alluminio lucido Piedino in faggio naturale sbiancato Piedino in faggio tinto ciliegio Piedino in faggio tinto noce Piedino in faggio tinto noce scuro Piedino in faggio tinto wengè

EASY

design marconato&zappa

Caratteristiche: Ampia gamma di soluzioni compositive grazie ai numerosi elementi disponibili. Contraddistinto da un perfetto equilibrio tra bracciolo e schienale, il divano Easy si pone come scelta senza tempo: un divano confortevole per tutte le case del mondo. Cuscini in morbida piuma con inserto in poliuretano o in poliuretano espanso speciale. Il divano Easy è completamente sfoderabile.

Struttura: **1**_Struttura in legno massello di abete. **2**_Pannelli di legno compensato. **3**_Pannelli di legno multistrati. **4**_Molleggio ottenuto con cinghie elastiche Intes Elabelt 790/4 larghezza 90 mm.

Imbottitura della struttura: **5**_Poliuretano espanso a densità differenziata T25 - PF30 - T40P - SR75. **6**_Vellutino accoppiato con espanso mm 10 TL/SC 200 gr. **7**_Accoppiato tessuto di cotone 100 gr. con vellutino.

Imbottitura dei cuscini versione piuma: **8**_Cuscini schienali in piuma d'oca bianca etichetta standard Assopiuma, con inserto in poliuretano espanso a densità differenziata PF21SM - PF25SM - T40. **9**_Cuscini sedili in piuma d'oca bianca etichetta standard Assopiuma, con inserto in poliuretano espanso a densità differenziata OS30FM - WLD35 - T40RC.

Imbottitura dei cuscini versione poliuretano: **8**_Cuscini schienali in poliuretano espanso a densità differenziata PF21SM - PF25SM + termolegato 400 gr. con fodera di cotone. **9**_Cuscini sedili in poliuretano espanso a densità differenziata EM40 - OS30FM + termolegato 400 gr. con fodera di cotone.

Rivestimento: **10**_Rivestimento in pelle o in tessuto completamente sfoderabile.

Finiture: **11**_Piedini in alluminio lucido oppure faggio naturale sbiancato o tinto: wengè, noce, noce scuro, ciliegio.

Characteristics: The variety of elements available can be used to form an extensive range of compositions. Distinguished by a perfect balance between armrest and backrest, the Easy sofa is a timeless choice: a comfortable sofa ready for homes all over the world. Soft, down-filled cushions with polyurethane or special polyurethane inner foam core. The Easy sofa has fully removable covers.

Structure; **1**_Pinewood frame. **2**_Plywood panels. **3**_Multilayer panels. **4**_Suspension obtained from 90 mm wide, Intes Elabelt 790/4 elastic belts.

Structure padding: **5**_Differentiated density expanded polyurethane T25 - PF30 - T40P - SR75. **6**_Velveteen coupled with foamed polyurethane mm 10 TL/SC 200 gr. **7**_Coupled cotton fabric 100 gr. with velveteen.

Cushions padding goose down type: **8**_Backrest cushions in white goose down Assopiuma standard label with foamed polyurethane insert at differentiated densities PF21SM - PF25SM - T40. **9**_Seat cushions in white goose down Assopiuma standard label with foamed polyurethane insert at differentiated densities OS30FM - WLD35 - T40RC.

Cushions padding polyurethane type: **8**_Backrest cushions in differentiated density expanded polyurethane PF21SM - PF25SM + heat bonded with 400 gr. cotton cover. **9**_Seat cushions in differentiated density expanded polyurethane EM40 - OS30FM + heat bonded with 400 gr. cotton cover.

Cover: **10**_Completely removable leather or fabric cover.

Finishing: **11**_Polished aluminium feet or beech-wood: natural bleached or tinted wengè, walnut, dark walnut, cherry.

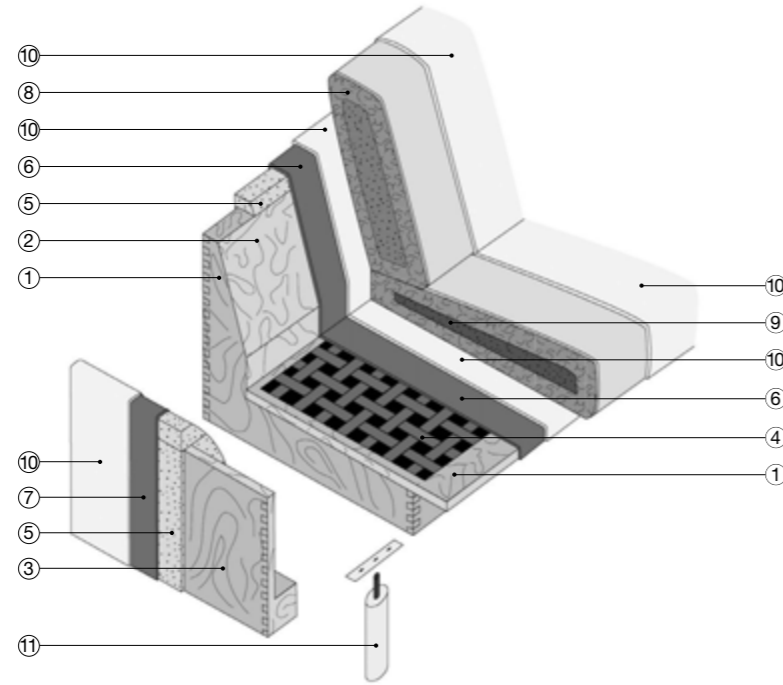

Composizione pagine 86/87

Divano Easy: rivestimento 1280/GH71 cat. G

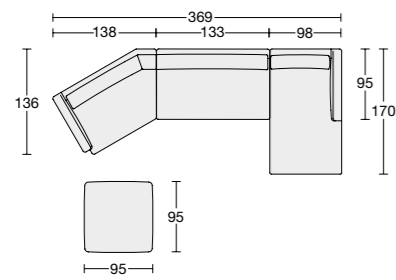

Composizione pagine 88/89

Divano Easy: rivestimento 1250/202 cat. EXTRA

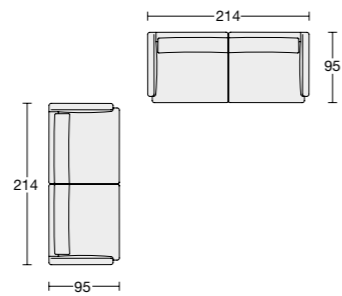

Composizione pagine 90/91

Divano Easy: rivestimento 1610/105 cat. EXTRA
Poltrona Easy: rivestimento 1610/105 cat. EXTRA

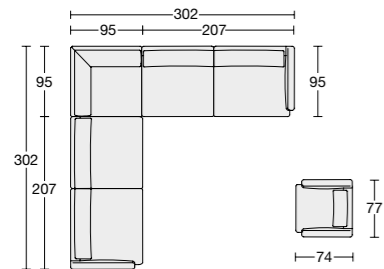

EASY 672/673

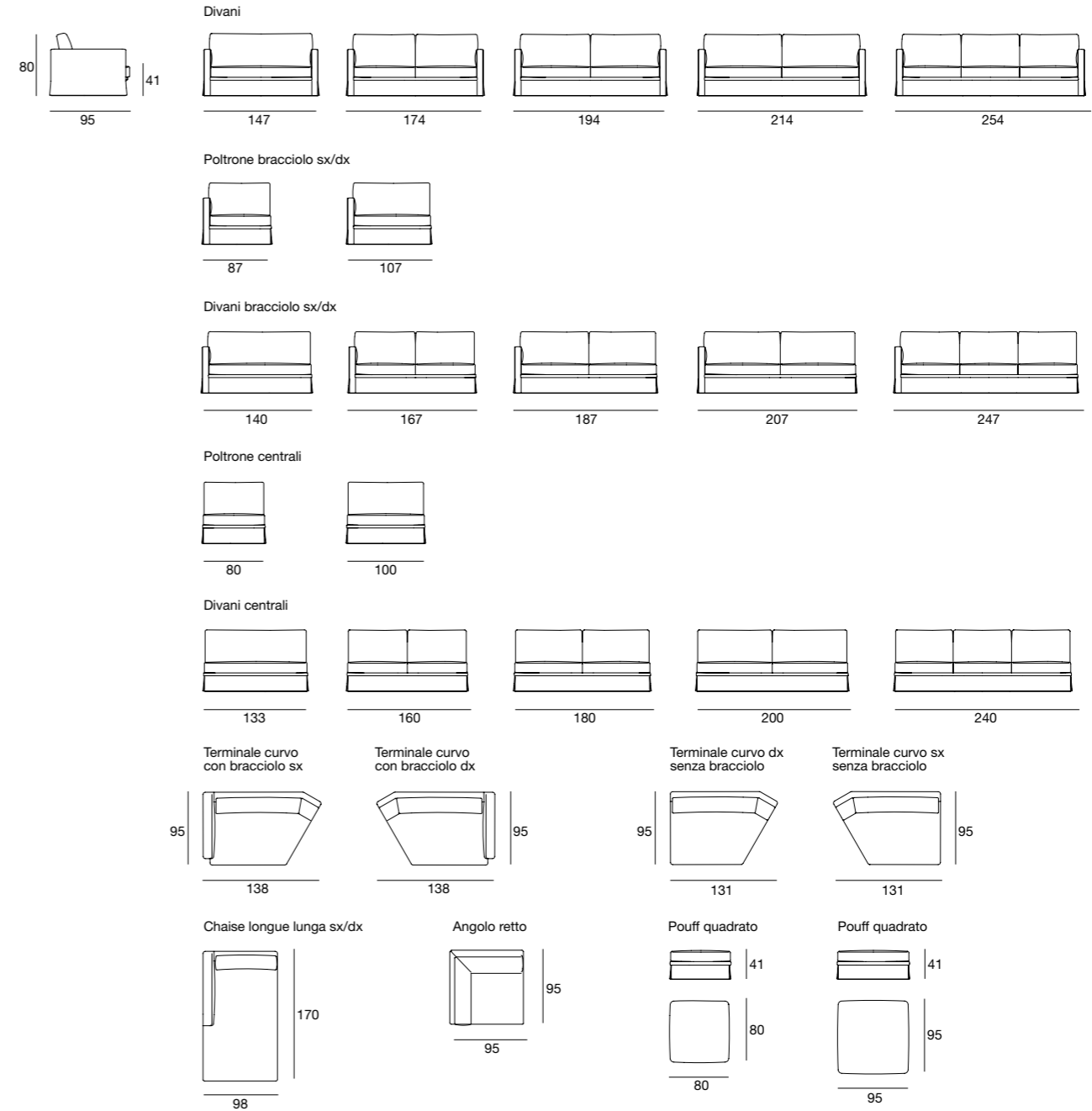

INGOMBRO TERMINALE CURVO

Terminale curvo con bracciolo da cm 138
Divano laterale di cm 140/167/187/207/247

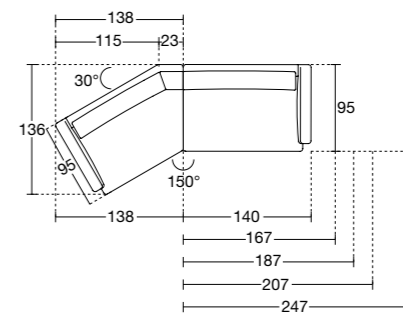

OPEN

design marconato&zappa

Caratteristiche: Creatività e fantasia suggeriscono una ampia gamma di soluzioni compositive. L'elegante curvatura del bracciolo esalta la sua decisa personalità. Il divano Open presenta una morbida cuscineria realizzata in piuma d'oca con inserto in poliuretano speciale. A richiesta, la cuscineria è realizzata totalmente con poliuretani speciali. Completamente sfoderabile, Open è proposto con piedini in alluminio lucido o in faggio tinto in vari colori.

Struttura: 1_Structura in legno multistrati. 2_Pannelli di legno compensato. 3_Molleggio ottenuto con cinghie elastiche Intes Elsbelt 790/4 larghezza 90 mm. **Imbottitura della struttura:** 4_Poliuretano espanso a densità differenziate Olmo T40 - T40 P, Orsa MTP 95. 5_Resinato 100 gr. accoppiato con cotone e con espanso 3 mm.

Imbottitura dei cuscini: 6_Cuscini sedile in piuma d'oca etichetta ORO, con inserto in poliuretano espanso a densità differenziate Sitab EM40, Olmo 35/M. 7_Cuscini schienali in piuma d'oca etichetta ORO, con inserto in poliuretano espanso a densità differenziate Olmo PF25/SM, Orsa WLD 25/S.

Rivestimento: 8_Rivestimento in pelle o in tessuto completamente sfoderabile. **Finiture** 9_Piedino in alluminio lucido o in faggio naturale sbiancato o tinto wengé, noce, noce scuro e ciliegio con supporto in alluminio.

Characteristics: Sinuous, sophisticated, exclusive styling is the key feature of the Open system of fixed and modular seating. The Open sofa has soft goose down cushions with a special polyurethane foam insert. Upon request, they can be filled entirely with special polyurethane foam. Open has completely removable upholstery and comes with feet made of polished aluminium or various shades of beech stained in various colours.

Structure: 1_Multilayer frame. 2_Plywood panels. 3_Suspension obtained from 90 mm wide, Intes Elsbelt 790/4 elastic belts. **Structure padding:** 3_Differentiated density expanded polyurethane Olmo T40 - T40 P, Orsa MTP 95. 4_Resin coupled with 100 gr cotton and 3 mm with foam. **Cushions padding:** 5_Seat cushion in ORO label goose down with foamed polyurethane insert at differentiated density Sitab EM40, Olmo 35/M. 6_Backrest cushion in ORO label goose down, with foamed polyurethane insert at differentiated density Olmo PF25/SM, Orsa WLD 25/S. **Cover:** 7_Completely removable leather or fabric cover. **Finishing:** 8_Polished aluminium feet or beech-wood: natural bleached or tinted wengé, walnut, dark walnut, cherry with aluminium support.

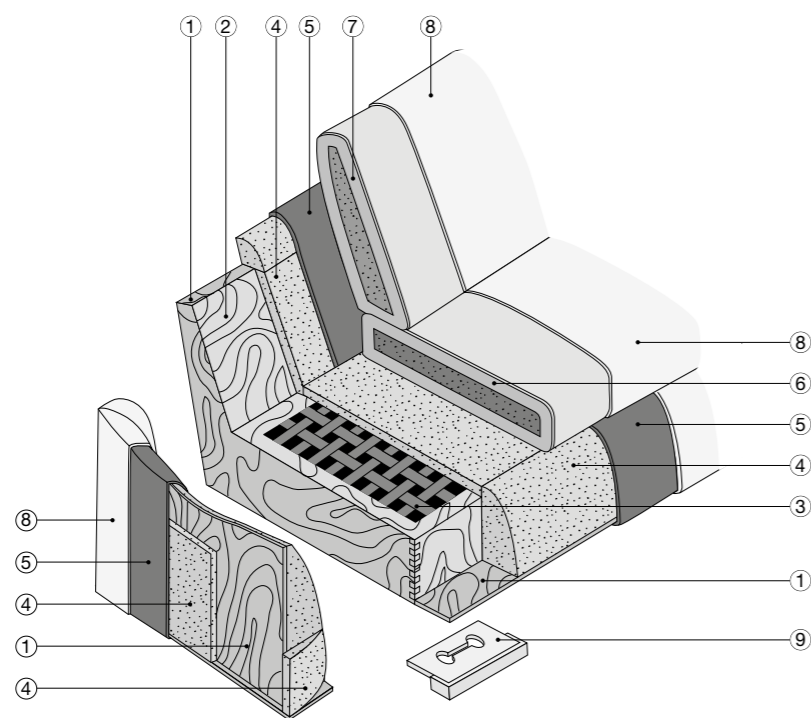

OPEN 660

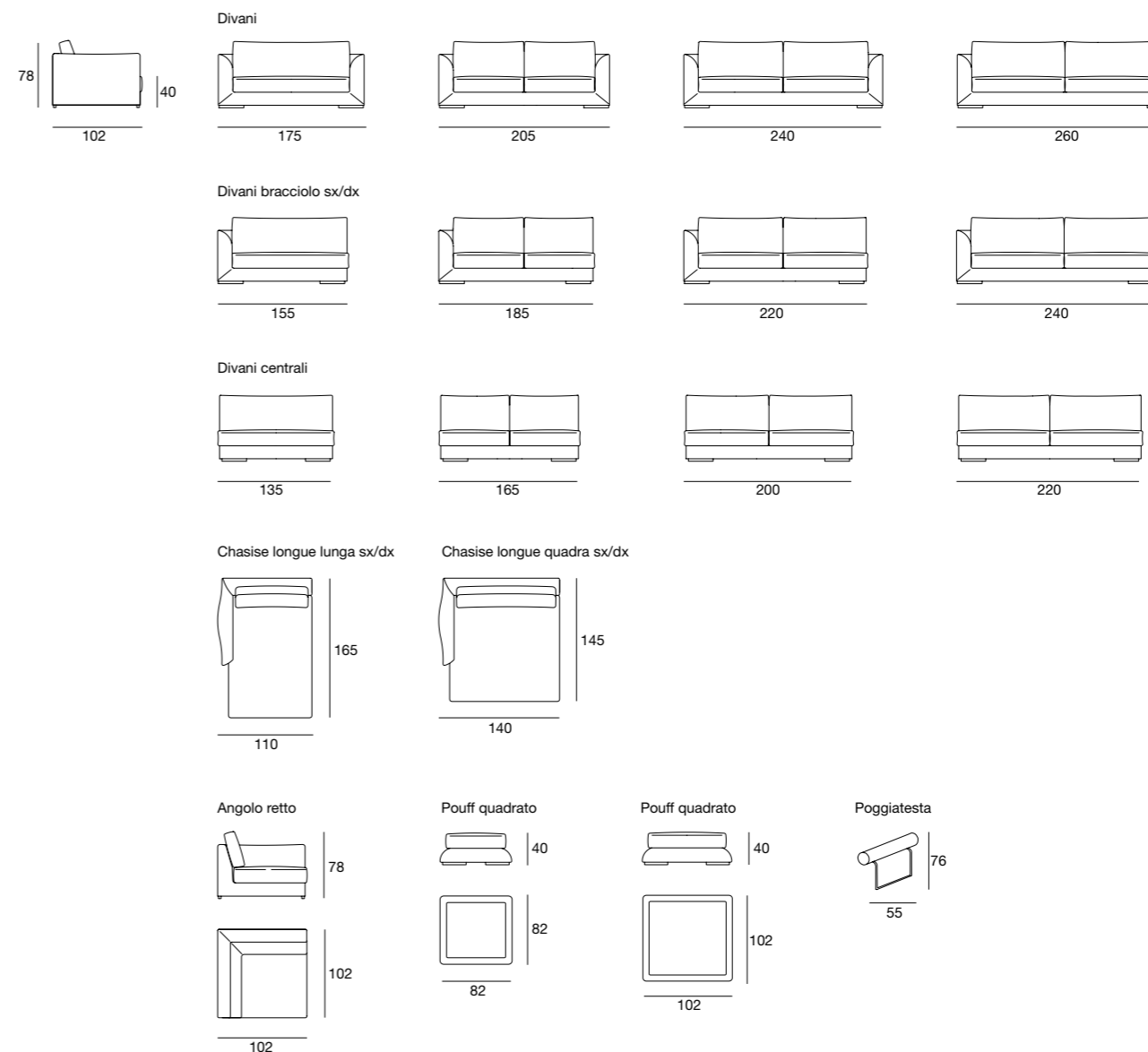

Composizione pagine 92/93

Divano Open: rivestimento 1570/09/01 cat. EXTRA e piedini in alluminio lucido
Pouff: rivestimento 1570/09/01 cat. EXTRA e piedini in alluminio lucido

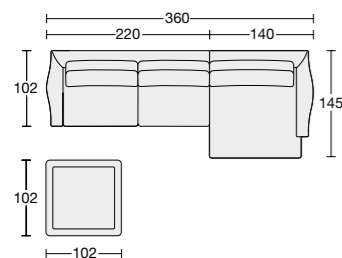

Composizione pagine 94/95

Divano Open: rivestimento pelle Diamante 718 cat. ANILINA piedini in alluminio lucido



Composizione pagine 96/97

Divano Open: rivestimento 1210/21 cat. EXTRALUX piedini in alluminio lucido

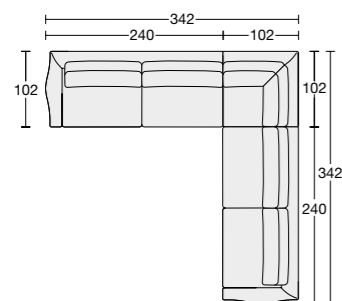

Variante Piedini



SPACE

design marconato&zappa

Caratteristiche: Straordinaria versatilità di soluzioni per Space. Space si presenta come prodotto di grande comodità per l'ampiezza della sua profondità. Caratteristica principale è il vero letto proposto con comoda ed ergonomica rete elettrosaldata. Space è completamente sfoderabili.

Struttura: 1_Structura in legno di abete. 2_Pannelli di legno compensato.

3_Molle ottenute con cinghie elastiche Elast 790/4 larghezza 90 mm.

Imbottitura della struttura: 4_Poliuretano espanso a densità differenziate T25 - T40/P - PF25/SM. 5_Resinato 100 gr. accoppiato con vellutino.

Imbottitura dei cuscini versione piuma: 6_Cuscini schienali in piuma d'oca, con inserto in poliuretano espanso a densità differenziate NIR 25/S - WLD/25S.

7_Cuscini sedili in piuma d'oca, con inserto in poliuretano espanso a densità differenziate WLD 35 rinforzi T40 + Lympha 35/M.

Imbottitura dei cuscini versione poliuretano: 6_Cuscini schienali in poliuretano espanso a densità differenziate NIR 25/S + WLD/25S rivestiti con fibra di Dacron accoppiata con cotone 400 gr. 7_Cuscini sedili in poliuretano espanso a densità differenziate WLD 35 rinforzi T40 + Lympha 35/M rivestiti con fibra di Dacron accoppiata con cotone 400 gr.

Rivestimento: 8_Rivestimento in pelle o in tessuto completamente sfoderabile.

Finiture: 9_Piedini in faggio tinto.

Characteristics: Extraordinarily versatile solutions for Space.

Space offers real comfort with its generous depth. The key feature is the real bed that comes with a comfortable, ergonomic-welded wire base. Space has fully removable covers.

Structure: 1_Pinewood frame. 2_Plywood panels.

3_Suspension obtained from 90 mm wide, Elast 790/4 elastic belts.

Structure padding: 4_Differentiated density expanded polyurethane T25 - T40/P - PF25/SM. 5_Resin 100 gr. coupled with velveteen.

Cushions padding goose down type: 6_Backrest in goose down with foamed polyurethane insert at differentiated densities NIR 25/S - WLD/25S.

7_Seat cushion in goose down with foamed polyurethane insert at differentiated densities WLD 35 reinforcement T40 + Lympha 35/M.

Cushions padding polyurethane type: 6_Backrest in foamed polyurethane at differentiated densities NIR 25/S + WLD/25S covered with Dacron fibre coupled with cotton 400 gr. 7_Seat cushion in foamed polyurethane WLD 35 reinforcement T40 + Lympha 35/M covered with Dacron fibre coupled with cotton 400 gr.

Cover: 8_Completely removable leather or fabric cover.

Finishing: 9_Stained beech feet.

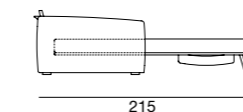
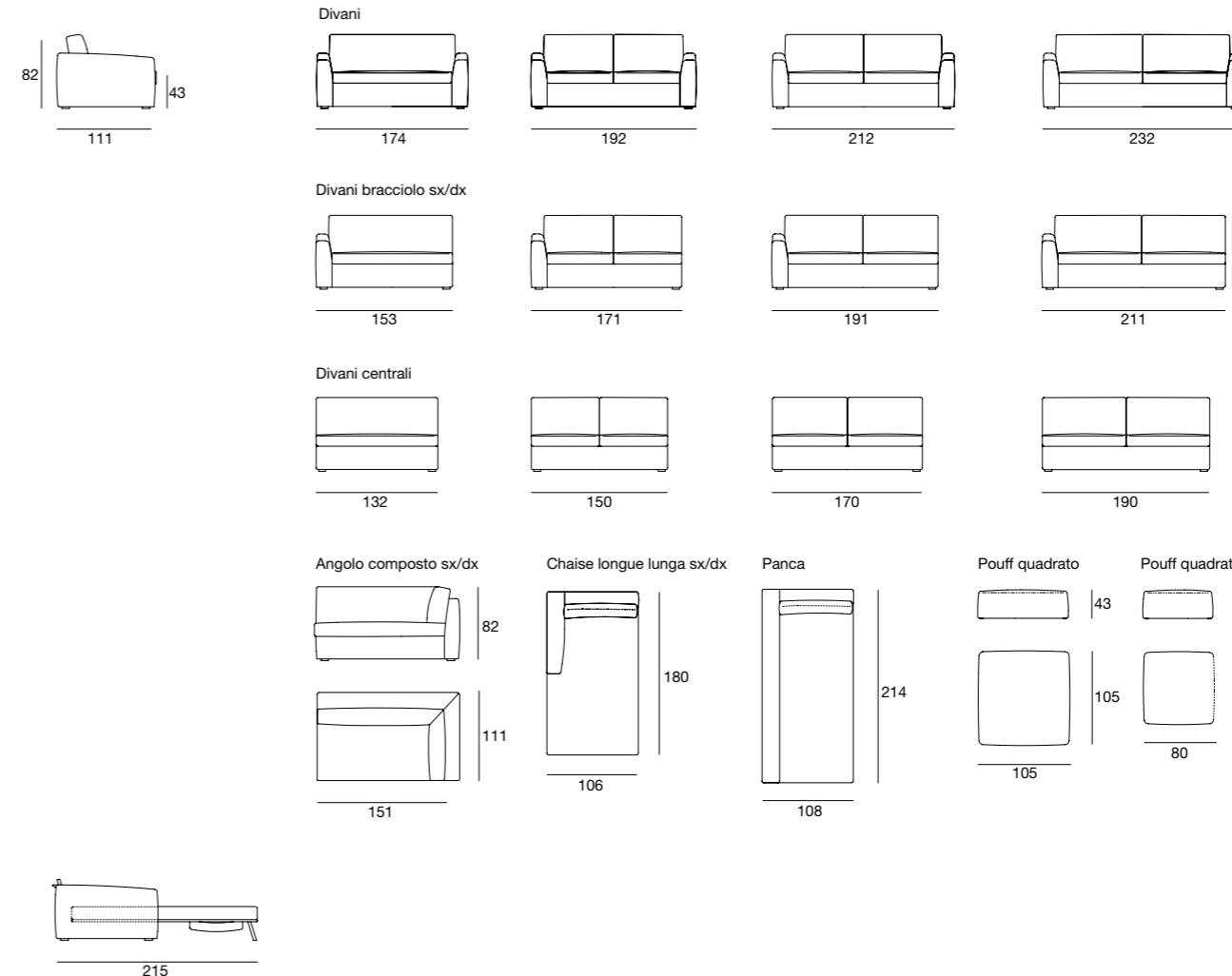
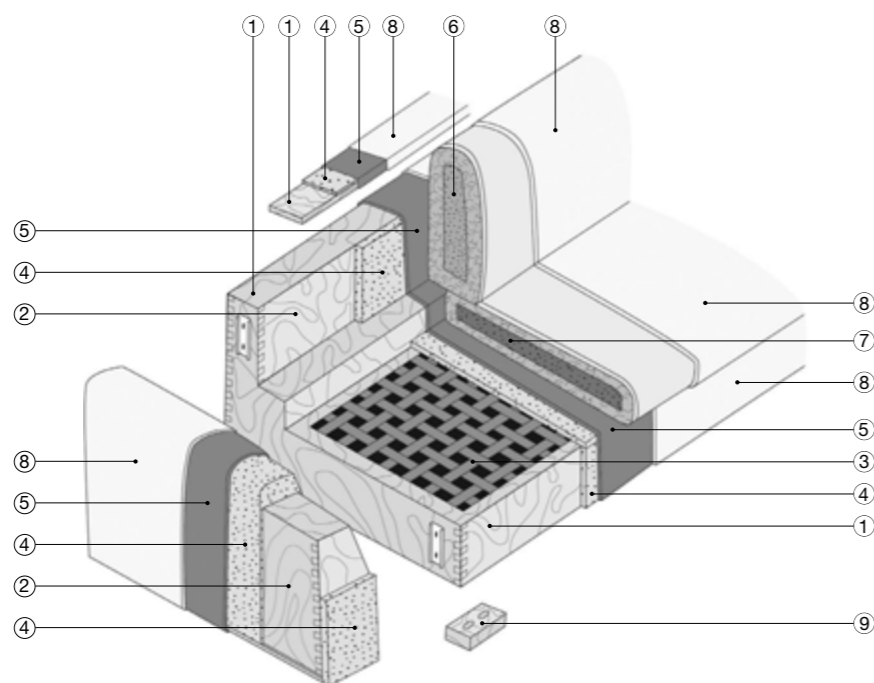

Il letto è fornito con rete elettrosaldata e materasso in espanso, densità 30 M rivestito in cotone trapuntato.
The bed is supplied with electrically welded base and mattress in expanded, density 30 M covered in quilted cotton.

La rete da cm 142 si può inserire nei divani cm 150/171/192 (materasso 120x200x11 h.) The cm 142 base can be fitted in sofas cm 150/171/192 (mattress 120x200x11 h.)
 La rete da cm 162 si può inserire nei divani cm 170/191/212 (materasso 140x200x11 h.) The cm 162 base can be fitted in sofas cm 170/191/212 (mattress 140x200x11 h.)
 La rete da cm 182 si può inserire nei divani cm 190/211/232 (materasso 160x200x11 h.) The cm 182 base can be fitted in sofas cm 190/211/232 (mattress 160x200x11 h.)

Composizione pagine 98/99

Divano Space: rivestimento pelle Diamante 870 cat. ANILINA



Composizione pagine 100/101

Divano Space: rivestimento 1230/1 cat. G
 Poltrona Diva: rivestimento 1020/100/4 cat. EXTRA

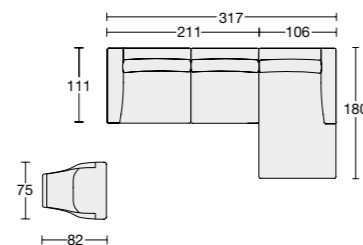

Composizione pagine 102/103

Divano Space: rivestimento 1240-01 cat. G

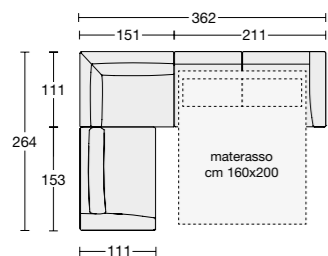

WELL_WELL SOFT

design marconato&zappa

Caratteristiche: Il sistema di sedute, caratterizzato da straordinaria versatilità, è proposto in due versioni: Well con cuscino schienale alto in poliuretano speciale, diviso in due parti e WellSoft con schienale arricchito da piccoli e grandi cuscini in morbida piuma. A richiesta, cuscini di seduta e schienale in piuma con inserto in poliuretano. Il sistema è completamente sfoderabile. Originale design dei piedini proposti in alluminio satinato, lucido e brunito.

Struttura: 1_Structura in legno di abete. 2_Pannelli di legno compensato.

3_Molleggio ottenuto con cinghie elastiche Intes Elsbelt 790/S larghezza 90 mm.

Imbottitura della struttura: 4_Poliuretano espanso a densità differenziate Olmo SR75, Olmo T40P e Olmo PF30. 5_Vellutino accoppiato TL 200 gr. e TL 100 gr. accoppiato 3 mm.

Imbottitura dei cuscini: 6_Cuscini schienale in poliuretano espanso a densità differenziate Olmo WLD 25/S e Olmo PS 25/SM termolegato 350 gr. e rivestiti con fodera di cotone per modello Well. Cuscini schienale in piuma rivestiti in fodera di cotone per modello WellSoft. 7_Cuscino seduta in poliuretano espanso a densità differenziate Olmo Ecoelast 40, Olmo T40RC e Olmo Viscoelastico 40 termolegato 350 gr. rivestito in fodera di cotone.

Rivestimento: 8_Rivestimento in pelle o in tessuto completamente sfoderabile.

Finiture: 9_Piedini in alluminio lucido, satinato o brunito.

Characteristics: The system of seats allows a wide range of solutions and is available in two models: Well, with high backrest cushion in special polyurethane divided in two parts, and WellSoft, whose backrest is enriched by small and big cushions filled with soft goose down. Both seat and backrest cushions may come with goose down and polyurethane insert upon request. All covers are completely removable. The original foot design can be in satined, polished or burnished aluminium.

Structure: 1_Fir wood frame. 2_Plywood panels. 3_Springing with elastic belts type Intes Elsbelt 790/4 width 90 mm.

Structure padding: 4_Foamed polyurethane at differentiated densities Olmo SR75, Olmo T40P and Olmo PF30. 5_Velveten coupled TL 200 gr. and TL 100 gr. coupled 3 mm.

Cushion padding: 6_Backrest cushion in foamed polyurethane at differentiated densities Olmo WLD 25/S and Olmo PS 25/SM heat-bonded 350 gr. and with cotton lining for Well model. Backrest cushion in goose down covered with cotton lining for WellSoft model. 7_Seat cushion in foamed polyurethane at differentiated densities Olmo Ecoelast 40, Olmo T40RC and Olmo Visco-elastic 40 heat-bended 350 gr. covered with cotton lining.

Cover: 8_Completely removable leather or fabric cover.

Finishing: 9_Feet in polished, satined or burnished aluminium.

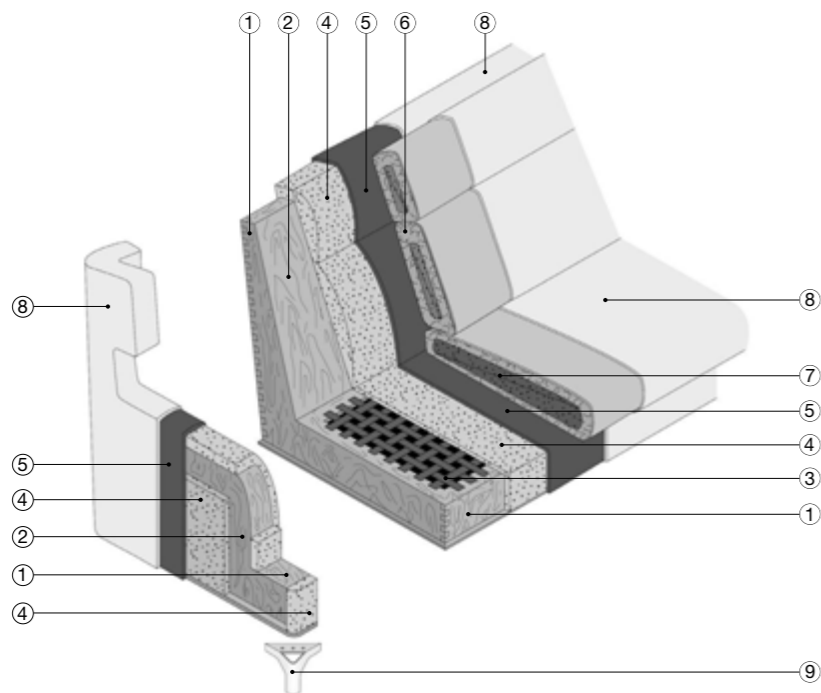

Composizione pagine 104/105

Divano Well: rivestimento pelle Nabuk 15 e piedini alluminio brunito

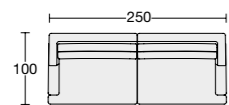

Composizione pagine 106/107

Divano Well: rivestimento 1300-1/4 cat. H e piedini alluminio satinato
Poltrona Well: rivestimento 1470/2003 cat. EXTRALUX e piedini alluminio satinato

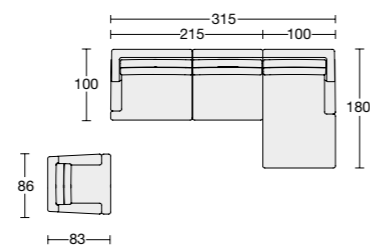

Composizione pagine 108/109

Divano WellSoft: rivestimento struttura, cuscini e seduta 1570/01 cat. EXTRA
cuscini piccoli 1320/21 cat. H e piedini alluminio lucido
Pouf: rivestimento 1320/21 cat. H e piedini alluminio lucido

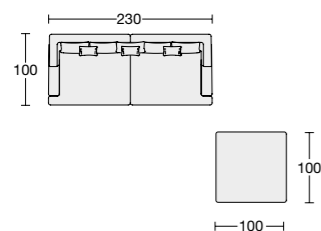

WELL 682

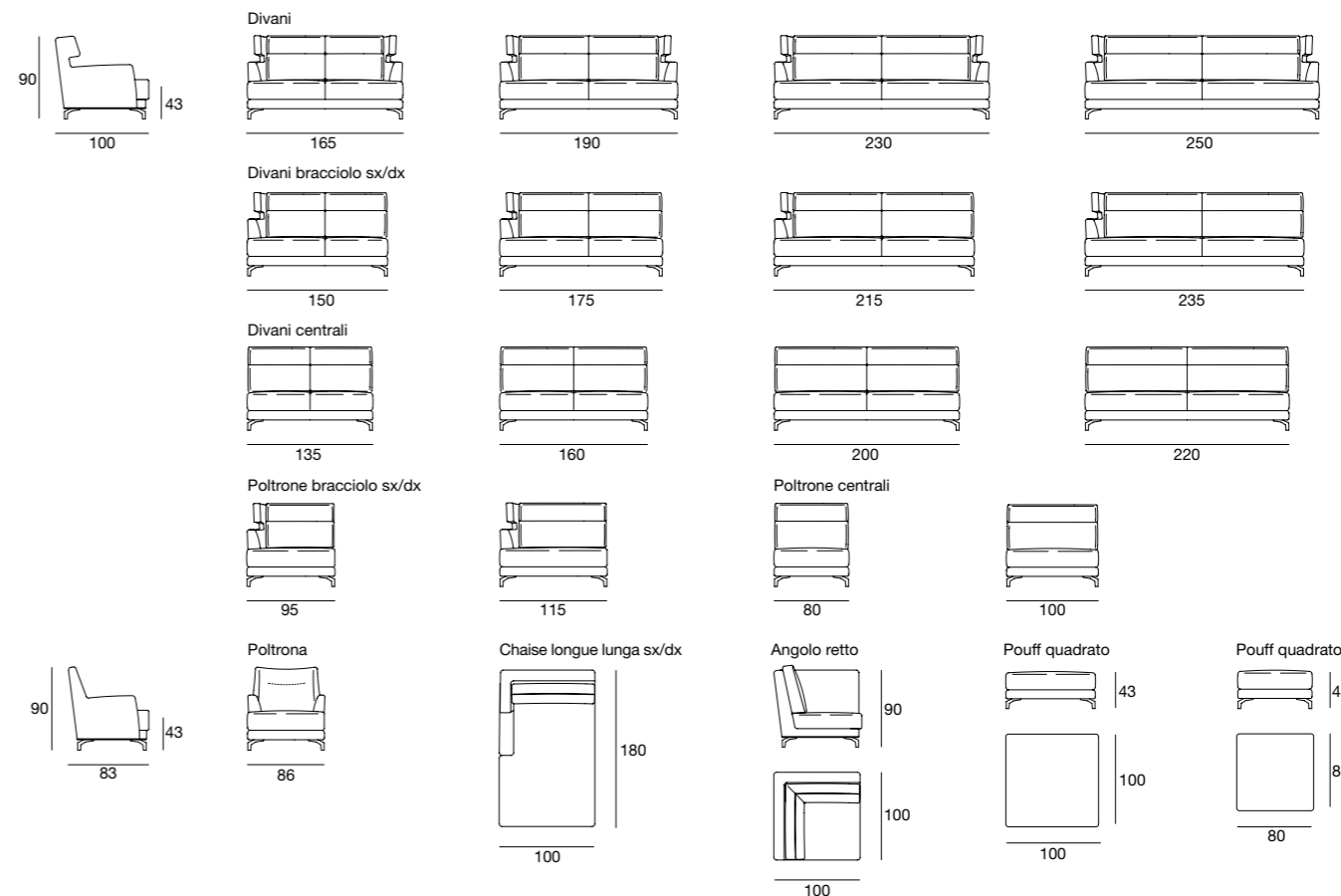

WELL SOFT 683

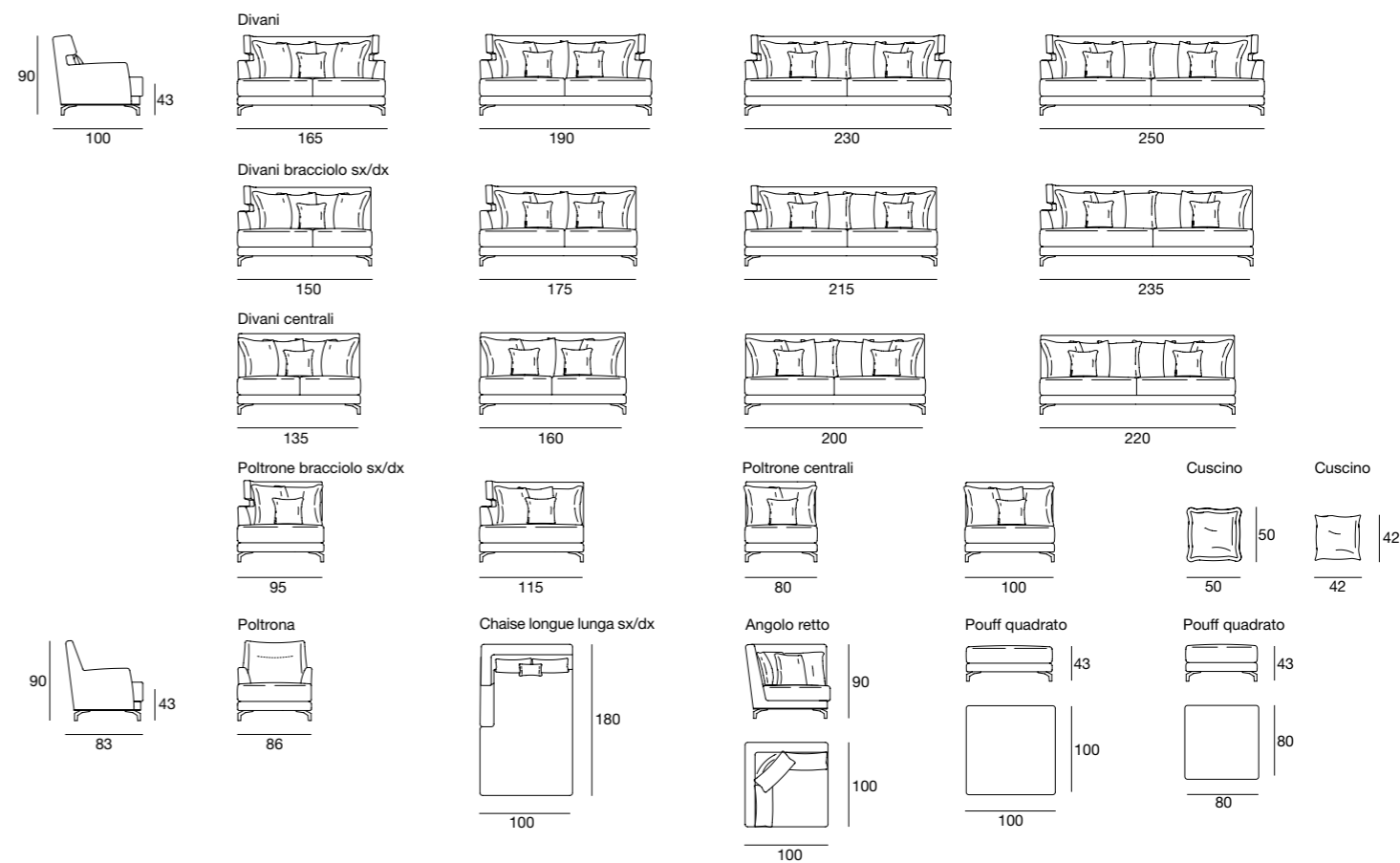

Varianti piedini



Piedino in alluminio lucido Piedino in alluminio satinato Piedino in alluminio brunito

Caratteristiche: Il modello Smart si propone con una vasta gamma di elementi fissi e componibili fra loro. Dettaglio di qualità è la lavorazione con doppia cucitura. Smart si presenta con due varianti di cuscinatura: la prima è in piuma d'oca mentre la seconda è in poliuretano ed è disponibile con l'inserimento di un comodo letto con rete ortopedica. Smart è completamente sfoderabile.

Struttura: 1 _Struttura in legno di abete. **2** _Pannelli di legno compensato.

3 _Molleghio ottenuto con cinghie elastiche Intes Elabelt 790/4 larghezza 90 mm.

Imbottitura della struttura: 4 _Poliuretano espanso a densità differenziate D/40 Vefer e P/25 Vefer. **5** _Vellutino accoppiato con espanso mm 10 TL/SC 200 gr.

Imbottitura dei cuscini versione piuma: 6 _Cuscino schienale in piuma d'oca ORO, con inserto in poliuretano espanso densità D/21SM Olmo.

7 _Cuscino sedile in piuma d'oca ORO, con inserto in poliuretano espanso a densità differenziata D/40 Lympha Olmo e D/40P Olmo.

Imbottitura dei cuscini versione poliuretano: 6 _Cuscino schienale in poliuretano espanso a densità differenziata Olmo D/25SM e Olmo D/21SM. Rivestiti con fibra di Dacron accoppiata con cotone 400 gr. **7** _Cuscino sedile in poliuretano espanso a densità differenziata Vefer D/35 Ergolattex e D/30 SP. Rivestiti con fibra di Dacron accoppiata con cotone 400 gr.

Rivestimento: 8 _Rivestimento in pelle o in tessuto completamente sfoderabile.

Finiture: 9 _Piedini in legno di faggio tinto.

Characteristics: Smart model comes with a wide range of fixed and modular parts which can be arranged among themselves. The double stitch pattern construction is synonym for top quality. Smart has two types of cushions: filled with goose down and with polyurethane, the latter model allowing to accommodate a comfortable bed. Smart has completely removable covers.

Structure: 1 _Fir wood frame. **2** _Plywood panels.

3 _Springing with elastic belts type Intes Elabelt 790/4 width 90 mm.

Structure padding: 4 _Foamed polyurethane at differentiated densities D/40 Vefer and P/25 Vefer. Velveteen coupled with foamed polyurethane mm 10 TL/SC 200 gr.

CUSHIONS PADDING GOOSE DOWN type Backrest cushion in ORO goose down, with foamed polyurethane insert density D/21SM Olmo.

5 _Seat cushion in ORO goose down with foamed polyurethane insert at differentiated densities D/40 Lympha Olmo and D/40P Olmo.

Cushion padding polyurethane type: 6 _Backrest cushion in foamed polyurethane at various densities Olmo D/25SM and Olmo D/21SM. Covered with Dacron fibre coupled with cotton 400 gr. **7** _Seat cushion in foamed polyurethane at differentiated densities Vefer D/35 Ergolattex and D/30 SP. Covered with Dacron fibre coupled with cotton 400 gr.

Cover: 8 _Completely removable leather or fabric cover.

Finishing: 9 _Stained beech feet.

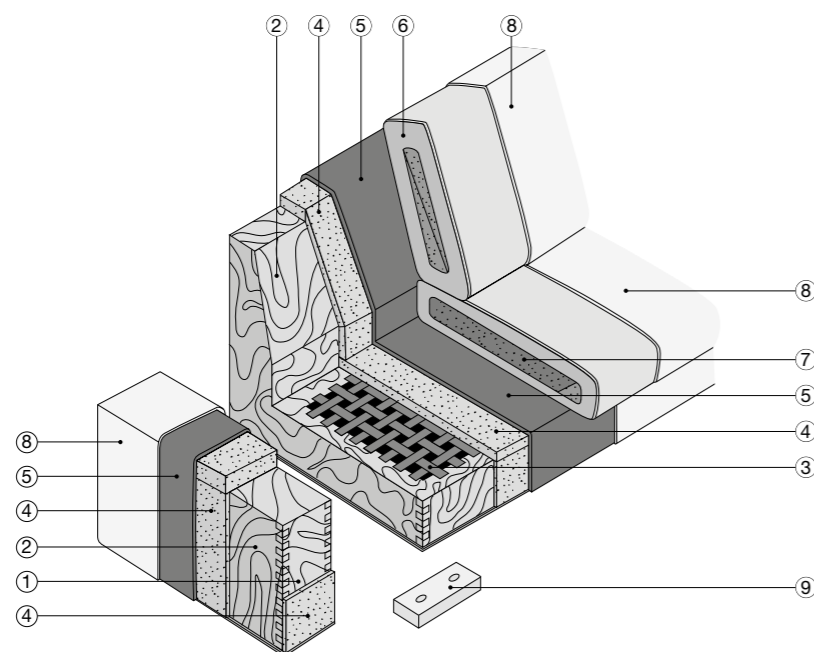
Composizione pagine 110/111

Divano Smart versione Piuma: rivestimento pelle Diamante 870 bianco cat. ANILINA

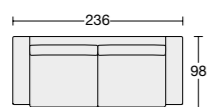
Composizione pagine 112/113

Divano Smart versione Piuma: rivestimento 1120/01 cat. G
 Pouff: rivestimento 1120/01 cat. G

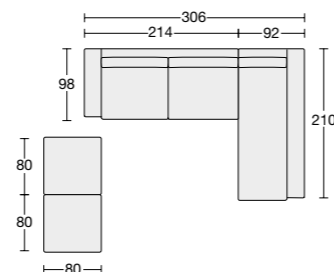
Composizione pagine 114/115

Divano Smart: rivestimento 1610-115 cat. EXTRA
 con letto rete doghe Lusso, rivestimento 1110/LL1 cat. G

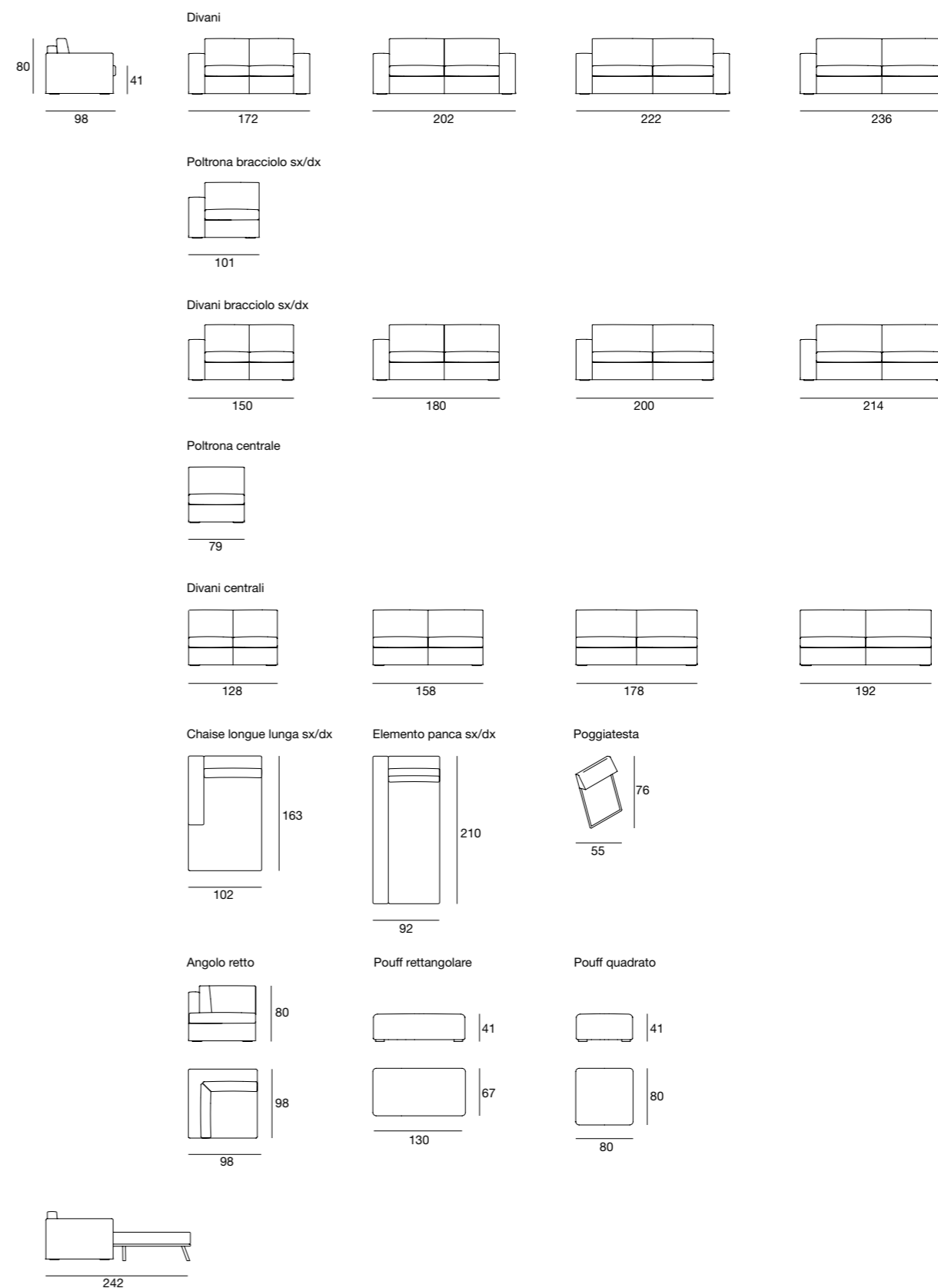
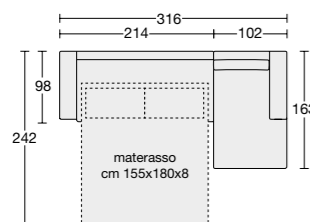

Il letto è disponibile solo nella versione poliuretano, con rete ortopedica a doghe in faggio o rete a maglia.
The bed is available only in polyurethane type, with orthopaedic base with beech wood slats or link mesh.

La rete da cm 122 si può inserire nei divani cm 128/150/172 (materasso 105x180x8 h.) The cm 122 base can be fitted in sofas cm 128/150/172 (mattress 105x180x8 h.)

La rete da cm 152 si può inserire nei divani cm 158/180/202 (materasso 135x180x8 h.) The cm 152 base can be fitted in sofas cm 158/180/202 (mattress 135x180x8 h.)

La rete da cm 172 si può inserire nei divani cm 178/192/200/214/222/236 (materasso 155x180x8h.) The cm 172 base can be fitted in sofas cm 178/192/200/214/222/236 (mattress 155x180x8 h.)

TIME

design marconato&zappa

Struttura: 1_Structura in multistrato di pioppo mm 30.
2_Molleggio ottenuto con cinghie elastiche Intes Elabelt 790/S larghezza mm 90.

Imbottitura della struttura: 3_Poliuretano espanso a densità differenziata T75 e T25. 4_Resinato accoppiato con vellutino gr 200.

Imbottitura dei cuscini versione piuma: 5_Cuscino schienale in piuma d'oca SMOB 10 con inserto in poliuretani espanso a densità differenziata T30 e T21 piumex rivestito con fodera pelleovo di cotone. 6_Cuscino sedile in piuma d'oca SMOB 10 con inserto in poliuretano espanso a densità differenziata T30 e T40 rivestito con fodera pelleovo di cotone. 7_Cuscino bracciolo in poliuretano espanso T40 rivestito con termolegato accoppiato con tela 200 gr.

Imbottitura dei cuscini versione poliuretano: 5_Cuscino schienale in poliuretano espanso a densità differenziata SH30 e T21 SS rivestito con fibra di Dacron 400 gr accoppiato con tela di cotone. 6_Cuscino sedile in poliuretano espanso a densità differenziata T35 Eucalipto e T30 SM rivestito con fibra di Dacron 400 gr accoppiato con tela di cotone. 7_Cuscino bracciolo in poliuretano espanso T40 rivestito con termolegato accoppiato con tela 200 gr.

Rivestimento: 8_Rivestimento in pelle o in tessuto completamente sfoderabile.

Finiture: 9_Basamento in frassino tinto naturale, noce, noce scuro, wengé, bianco poro aperto e nero poro aperto.

Structure: 1_Poplar plywood frame (30 mm).

2_Elastic webbing suspension (90 mm wide, Intes Elabelt 790/S).

Structure padding: 3_Differentiated density polyurethane foam (T75 and T25).

4_Resin (200 gr) coupled with velveteen.

Cushion padding goose down type: 5_Back cushion in SMOB 10 goose down with differentiated density polyurethane foam (T30 and T21 piumex) covered with fine muslin. 6_Seat cushion in SMOB 10 goose down with differentiated density polyurethane foam (T30 and T40) covered with fine muslin. 7_Armrest cushion in polyurethane foam (T40) covered with Heat-bonded fibre (200 gr) coupled with cotton fabric.

Cushion padding polyurethane type: 5_Back cushion in differentiated density polyurethane foam (SH 30 and T21 SS), covered with Dacron (400 g) coupled with cotton fabric. 6_Seat cushion in differentiated density polyurethane foam (T35 Eucalipto and T30 SM), covered with Dacron (400 g) coupled with cotton fabric. 7_Armrest cushion in polyurethane foam (T40) covered with Heat-bonded fibre (200 gr) coupled with cotton fabric.

Cover: 8_Fully removable leather or fabric cover.

Finishing: 9_Base in ash wood - natural, walnut, dark walnut or wenge stain or white or black open-pore lacquer.

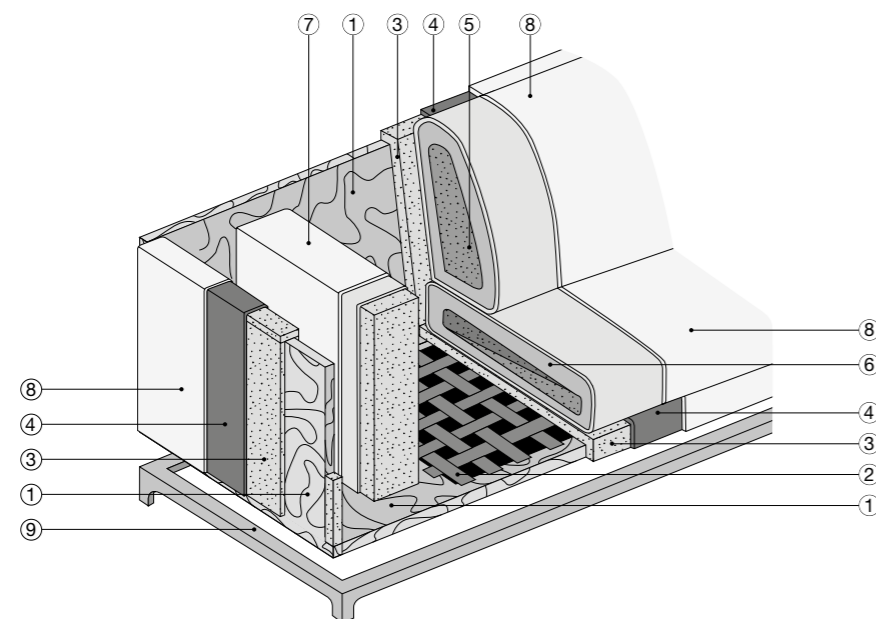

Composizione pagine 120/121

Poltrona Time: rivestimento 1590/92 cat. EXTRA profilo 136 sabbia
basamento frassino tinto noce scuro

TIME 705/706

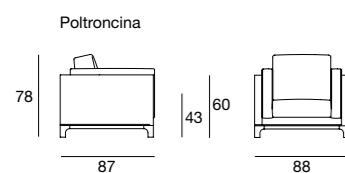

Varianti basamento



Frassino naturale Frassino tinto noce Frassino tinto noce scuro Frassino tinto wengé Frassino laccato bianco poro aperto Frassino laccato nero poro aperto

Varianti colori profilo

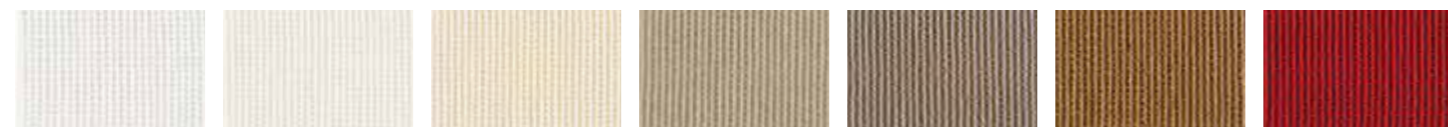

40 Bianco 36 Burro 37 Panna 136 Sabbia 164 Tortora 142 Nocciola 85 Rubino

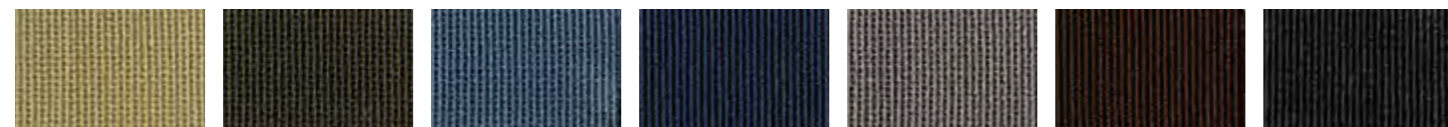

123 Pistacchio 175 Muschio 173 Avio 116 Oceano 46 Ferro 99 Moro 41 Nero

DANDY

design marconato&zappa

Struttura: 1_Pannello in legno compensato. 2_Molleggio ottenuto con cinghie elastiche Elabelt 790/4 larghezza 90 mm.

Imbottitura della struttura: 3_Sedile poliuretano espanso a densità differenziata T30 SPP e T30. 4_Schiena poliuretano a densità differenziata T21 SM e T40 P. 5_Resinato 100 gr accoppiato con vellutino.

Rivestimento: 6_Rivestimento in pelle o in tessuto.

Finiture: 7_Basamento in frassino naturale o tinto wengé, noce, noce scuro, e laccato a poro aperto bianco o nero. 8_Tavolino bracciolo in frassino naturale o tinto wengé, noce, noce scuro, e laccato a poro aperto bianco o nero.

Structure: 1_Plywood panel. 2_Elastic belt suspension (Elasbelt 790/4 width 90 mm).

Structure padding: 3_Seat in differentiated density polyurethane foam (T30 SPP and T30). 4_Back in differentiated density polyurethane (T21 SM and T40 P). 5_Resin (100 gr) coupled with velveteen.

Cover: 6_Leather or fabric cover.

Finishing: 7_Base in ashwood - natural or wengé, walnut, dark walnut stain or with white or black open-pore lacquer. 8_Armrest top in ashwood - natural or wengé, walnut, dark walnut stain or with white or black open-pore lacquer.

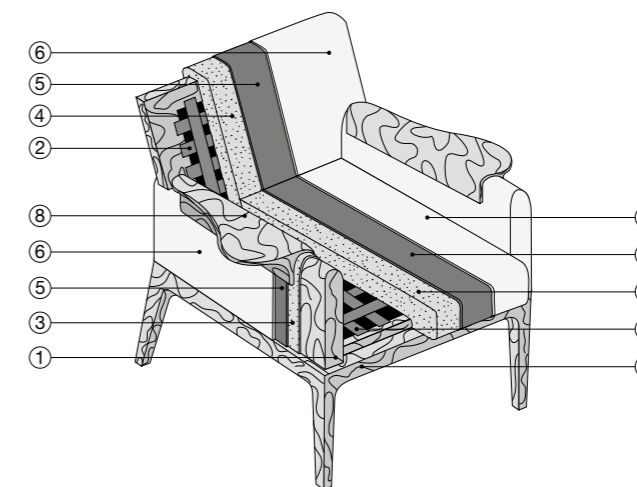

Composizione pagine 122/123

Poltrona Dandy: rivestimento 1550/1/12 cat. EXTRA
basamento tinto wengé

DANDY 703

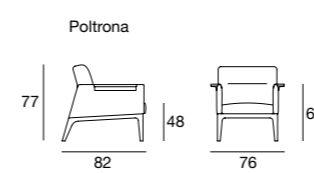

Varianti basamento e tavolino bracciolo in legno



Frassino naturale Frassino tinto noce Frassino tinto noce scuro Frassino tinto wengé Frassino laccato bianco poro aperto Frassino laccato nero poro aperto

PLAZA

design marconato&zappa

Struttura: 1_Pannello in legno di abete. 2_Pannello in legno di multistrato curvato. 3_Molle ottenuto con cinghie elastiche Elasmat 790/4 larghezza 90 mm.

Imbottitura della struttura: 4_Sedile poliuretano espanso a densità differenziata T30 SPP e T30. 5_Schienale poliuretano a densità differenziata T21 SM e T40 P.

6_Resinato 100 gr accoppiato con vellutino. 7_Cuscinetto poggiatesta in piuma d'oca ORO.

Rivestimento: 8_Rivestimento in pelle o in tessuto. 9_Struttura rivestita in cuoietto, pelle o in tessuto.

Finiture: 10_Piedini in frassino naturale o tinto wengé, noce, noce scuro, e laccato a poro aperto bianco, nero o rivestito in cuoietto o pelle.

Structure: 1_Fir wood panel. 2_Curved engineered wood panel. 3_Elastic belt suspension (Elasmat 790/4 width 90 mm).

Structure padding: 4_Seat in differentiated density polyurethane foam (T30 SPP and T30). 5_Back in differentiated density polyurethane (T21 SM and T40 P).

6_Resin (100 gr) coupled with velveteen. 7_Lower back cushion in ORO goose down.

Cover: 8_Leather or fabric cover. 9_Frame covered with cuoietto leather, leather or fabric.

Finishing: 10_Feet in ashwood – natural or wengé, walnut, dark walnut stain and with white or black open-pore lacquer or with cuoietto leather or leather cover.

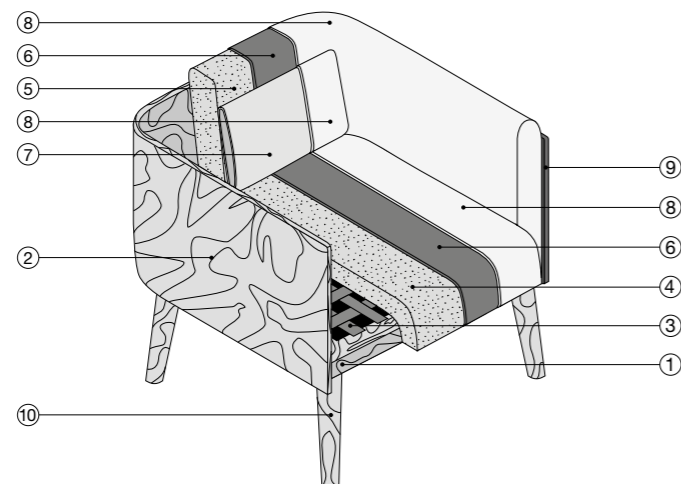

Composizione pagine 124/125

Poltrona Plaza: struttura e piedini in cuoietto colore testa di moro, cuscini rivestimento 1520/90 cat. EXTRALUX

PLAZA 704

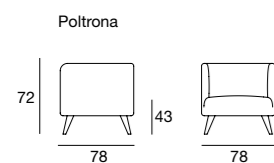

Varianti struttura e piedini in cuoietto



Varianti piedini in legno

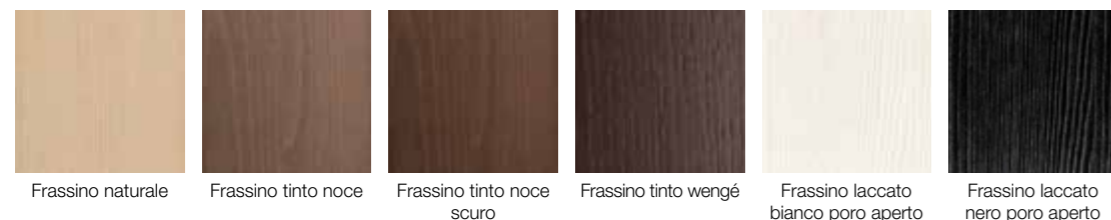

REBECCA

design marconato&zappa

Struttura: 1_Struttura in metallo.

Imbottitura della struttura: 2_Poliuretano espanso schiumato a freddo ignifugo classe 1.IM. 3_Resinato accoppiato 100 gr.

Imbottitura dei cuscini: 4_Cuscino seduta in poliuretano espanso densità EM 40 rivestito con fibra di Dacron 400 gr accoppiato con tela di cotone.

Rivestimento: 5_Rivestimento in pelle o in tessuto completamente sfoderabile.

Finiture: 6_Piedini in frassino tinto o base girevole in acciaio verniciato.

Structure: 1_Metal frame.

Structure padding: 2_Cold-moulded polyurethane foam class 1.IM fire-retardant. 3_Coupled resin 100 gr.

Cushions padding: 4_Seat cushions in density polyurethane foam EM 40 covered with Dacron fibre 400 gr coupled with cotton fabric.

Cover: 5_Completely removable leather or fabric cover.

Finishing: 6_Feet in ashwood stained or base rounded in painted steel.

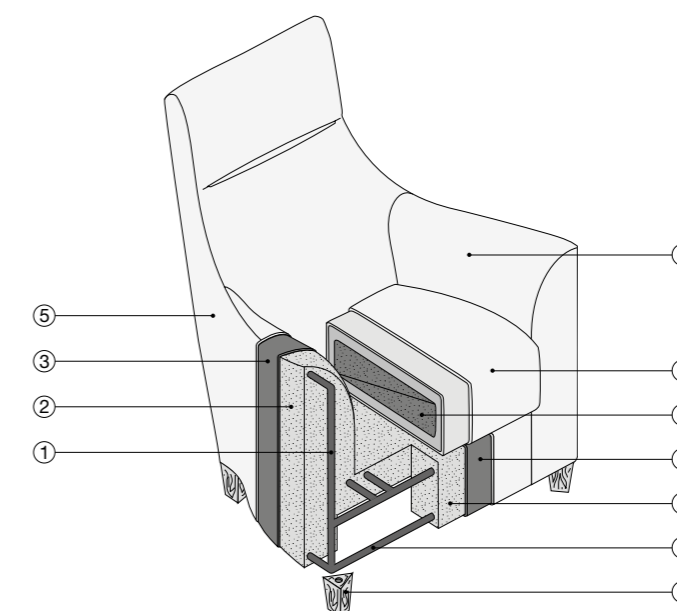

Composizione pagina 126

Poltrona Rebecca fissa: rivestimento 1440/18 cat. EXTRA e piedini frassino tinto nero poro aperto

Composizione pagina 127

Poltrona Rebecca girevole: rivestimento pelle Cristal 51 cat. ANILINA con basamento girevole brun sablé

Rebecca 690

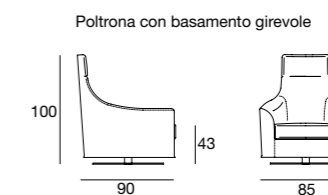
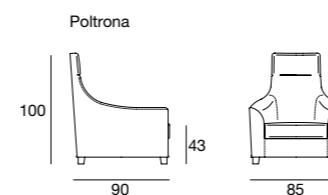

ELLIOT

design marconato&zappa

Struttura: 1_Struttura basamento in frassino. 2_Telaio metallo verniciato. 3_Struttura legno di abete.
4_Molleggio con cinghie elastiche Intes Elabest larghezza 60mm. 5_Perni e viti per il montaggio.
Imbottitura della struttura: 6_Poliuretano espanso T35. 7_Poliuretano espanso T40.
Imbottitura dei cuscini: 8_Cuscino seduta in piuma d'oca ORO, con inserto in poliuretano espanso a densità differenziata T30 SP e T35 SM rivestito in pelle/ovino di cotone.
Rivestimento: 9_Rivestimento in pelle o in tessuto.
Finiture basamento: 10_Basamento in legno di frassino naturale, tinto noce, tinto noce scuro, tinto wengè, in frassino laccato bianco o nero poro aperto oppure completamente rivestito. 11_Puntali ovali in alluminio lucido con feltrino.

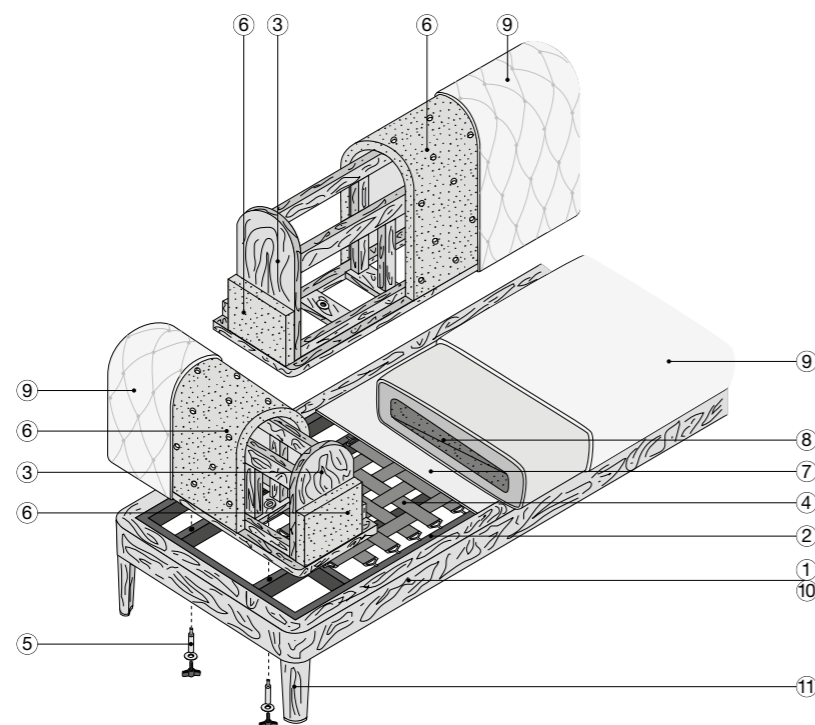

Structure: 1_Ashwood base frame. 2_Painted metal frame. 3_Fir wood frame.
4_Elastic belt suspension Intes Elabest width 60mm. 5_Pins and screws for installation.
Structure padding: 6_Polyurethane foam T35. 7_Polyurethane foam T40.
Cushion padding: 8_Seat cushions in ORO goose down, with insert in differentiated density polyurethane foam T30 SP and T35 SM covered with fine muslin.
Cover: 9_Leather or fabric cover.
Finishing base: 10_Base in natural ashwood stained walnut, dark walnut, wengè or in ashwood with white or black open-pore lacquer or completely covered. Oval, polished aluminium foot caps with felt pads.

Composizione pagina 128

Chaise longue dx Elliot tutta imbottita: rivestimento velluto 1470/28 cat EXTRALUX

Composizione pagina 129

Poltroncine Elliot: rivestimento velluto 1470/2012 cat. EXTRALUX e basamento frassino tinto wengè

ELLIOT 692 BASAMENTO IMBOTTITO

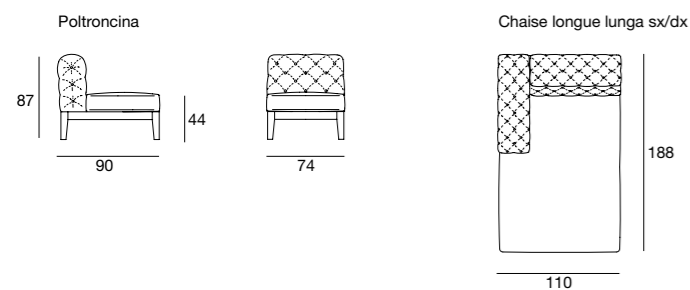

ELLIOT 691 BASAMENTO LEGNO

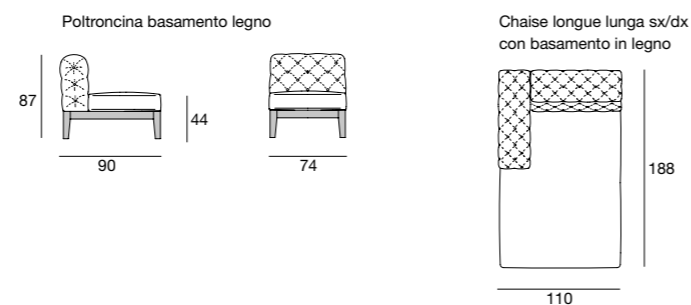

Varianti basamento e tavolino bracciolo in legno

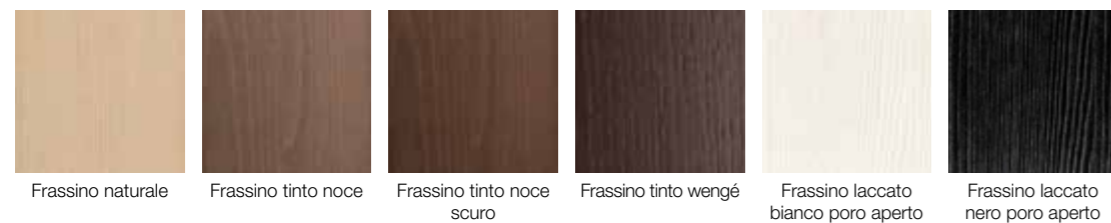

ELLE

esetidesign

Struttura: 1_Struttura in acciaio.
2_Molleggio ottenuto con cinghie elastiche Intes Elabest 50 mm.
Imbottitura della struttura: 3_Poliuretano schiumato a freddo ignifugo. 4_Vellutino accoppiato 3 mm.
Rivestimento: 5_Rivestimento in pelle o in tessuto sfoderabile.
Finiture: 6_Basamento in metallo cromato lucido girevole o basamento fisso in legno di frassino tinto naturale, noce, noce scuro, wengè, bianco e nero.

Structure: 1_Steel structure.
2_Elastic belt suspension (Intes Elabest width 50 mm).
Structure padding: 3_Fire-retardant, cold-moulded polyurethane foam. 4_Velour coupling 3 mm.
Cover: 5_Removable leather or fabric cover.
Finishing: 6_Glossy chrome swivel base or ashwood fixed base natural, walnut, dark walnut or wenge stain or white and black.

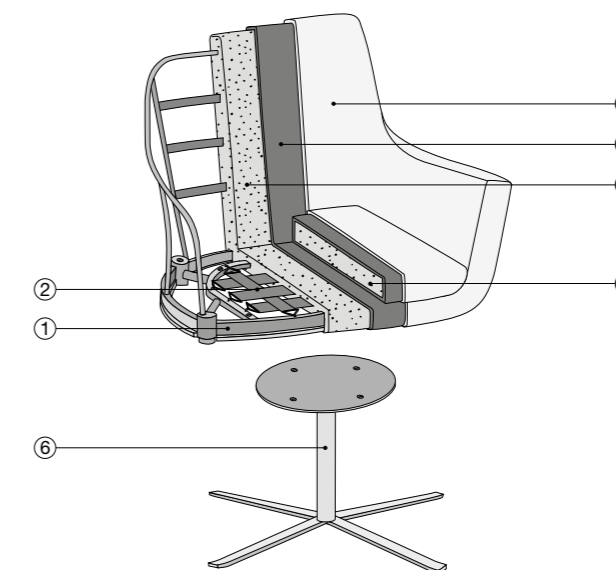

Composizione pagina 130

Poltrona Elle fissa: rivestimento 1520/89 cat. EXTRALUX basamento frassino tinto wengè

Composizione pagina 131

Poltrona Elle girevole: rivestimento 1490/80 cat. H basamento cromato lucido

ELLE 696

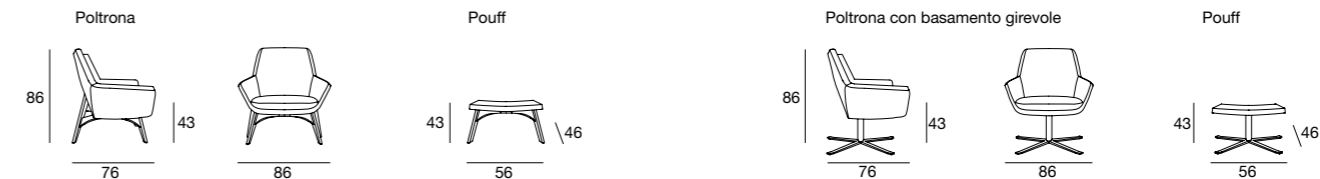

Basamento girevole in metallo



Cromato lucido

Varianti basamento fisso in legno



Frassino naturale

Frassino tinto noce

Frassino tinto noce scuro

Frassino tinto wengè

Frassino tinto bianco poro aperto

Frassino tinto nero poro aperto

DANA

esetidesign

Struttura: 1_ Struttura in poliuretano rigido strutturale POLTRONG.
Imbottitura della struttura: 2_Poliuretano schiumato a freddo ignifugo.
 3_Vellutino accoppiato 3 mm.
Rivestimento: 4_ Rivestimento in pelle o in tessuto sfoderabile.
Finiture: 5_Basamento in metallo cromato lucido girevole o basamento fisso in legno di frassino tinto naturale, noce, noce scuro, wengé, bianco e nero.

Structure: 1_Firm POLTRONG polyurethane foam structure.
Structure padding: 2_Fire-retardant, cold-moulded polyurethane foam.
 3_Velour coupling 3 mm.
Cover: 4_Removable leather or fabric cover.
Finishing: 5_Glossy chrome swivel base or ashwood fixed base natural, walnut, dark walnut or wenge stain or white and black.

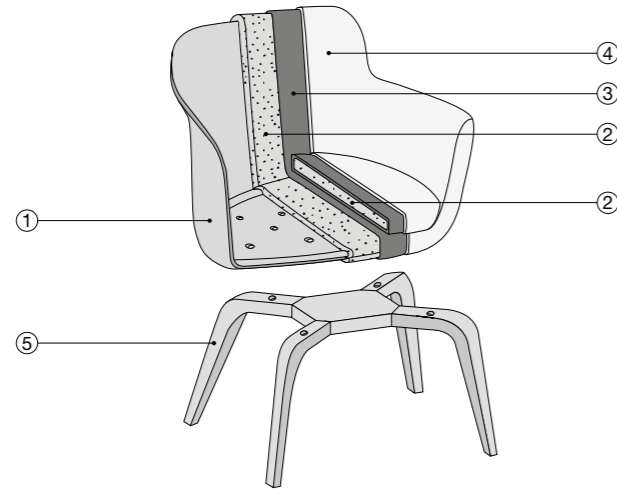

Composizione pagina 132

Poltrona Dana girevole: rivestimento 1520/72 cat. EXTRALUX
 basamento cromato lucido

Composizione pagina 133

Poltrona Dana fissa: rivestimento 1490/82 cat. H
 basamento frassino tinto noce scuro

DANA 698

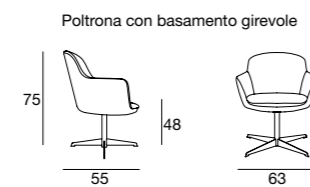
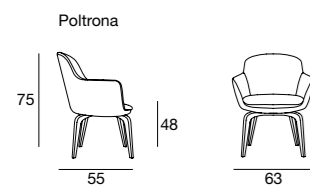

Basamento girevole in metallo



Cromato lucido

Varianti basamento fisso in legno



Frassino naturale



Frassino tinto noce



Frassino tinto noce scuro



Frassino tinto wengé



Frassino tinto bianco poro aperto



Frassino tinto nero poro aperto

ANNA

esetidesign

Struttura: 1_Structura in acciaio.
 2_Molleggio ottenuto con cinghie elastiche Intes Elabelt 50 mm.
Imbottitura della struttura: 3_Poliuretano schiumato a freddo ignifugo.
 4_Vellutino accoppiato 3 mm.
Rivestimento: 5_Rivestimento in pelle o in tessuto sfoderabile.
Finiture: 6_Basamento in metallo cromato lucido girevole o basamento fisso in legno di frassino tinto naturale, noce, noce scuro, wengé, bianco e nero.

Structure: 1_Steel structure.
 2_Elastic belt suspension (Intes Elabelt width 50 mm).
Structure padding: 3_Fire-retardant, cold-moulded polyurethane foam.
 4_Velour coupling 3 mm.
Cover: 5_Removable leather or fabric cover.
Finishing: 6_Glossy chrome swivel base or ashwood fixed base natural, walnut, dark walnut or wenge stain or white and black.

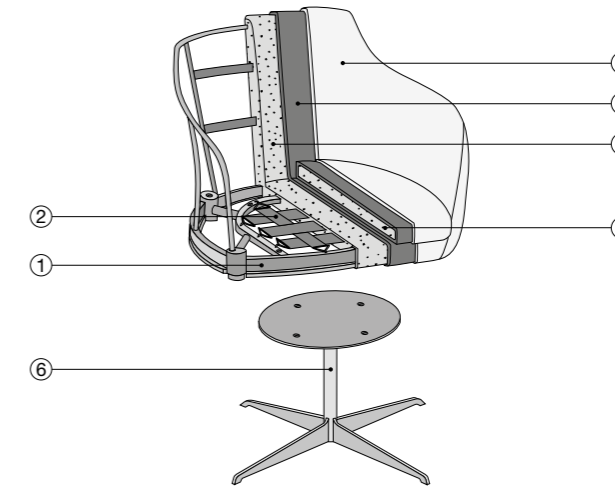

Composizione pagina 134

Poltrona Anna fissa: rivestimento 1520/10 cat. EXTRALUX
 basamento frassino tinto noce scuro

Composizione pagina 135

Poltrona Anna girevole: rivestimento 1460/12 cat. H
 basamento cromato lucido

ANNA 695

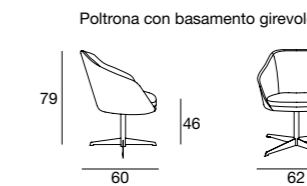
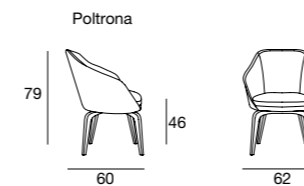

Basamento girevole in metallo



Cromato lucido

Varianti basamento fisso in legno



Frassino naturale



Frassino tinto noce



Frassino tinto noce scuro



Frassino tinto wengé



Frassino tinto bianco poro aperto



Frassino tinto nero poro aperto

MEGAN

esetidesign

Struttura: 1_Structura in acciaio.
2_Molleggio ottenuto con cinghie elastiche Intes Elabelt 50 mm.
Imbottitura della struttura: 3_Poliuretano schiumato a freddo ignifugo.
4_Vellutino accoppiato 3 mm.
Rivestimento: 5_Rivestimento in pelle o in tessuto sfoderabile.
Finiture: 6_Basamento in metallo cromato lucido girevole o basamento fisso in legno di frassino tinto naturale, noce, noce scuro, wengé, bianco e nero.

Structure: 1_Steel structure.
2_Elastic belt suspension (Intes Elabelt width 50 mm).
Structure padding: 3_Fire-retardant, cold-moulded polyurethane foam.
4_Velour coupling 3 mm.
Cover: 5_Removable leather or fabric cover.
Finishing: 6_Glossy chrome swivel base or ashwood fixed base natural, walnut, dark walnut or wenge stain or white and black.

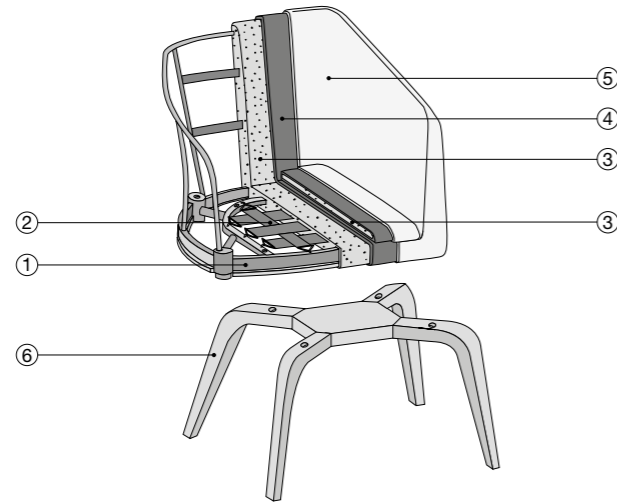

Composizione pagina 136

Poltrona Megan fissa: rivestimento 1500/02 cat. EXTRA
 basamento frassino tinto noce scuro

Composizione pagina 137

Poltrona Megan girevole: rivestimento 1510/03 cat. EXTRALUX
 basamento cromato lucido

Megan 697

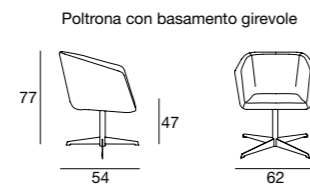
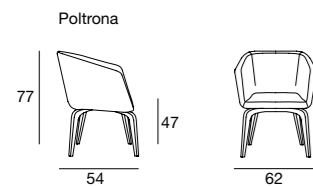

Basamento girevole in metallo



Cromato lucido

Varianti basamento fisso in legno



Frassino naturale



Frassino tinto noce



Frassino tinto noce scuro



Frassino tinto wengé



Frassino tinto bianco poro aperto



Frassino tinto nero poro aperto

GLEE

design marconato&zappa

Struttura: 1_Structura in legno di abete. 2_Pannelli di legno compensato. 3_Molleggio ottenuto con cinghie elastiche Intes Elabelt 790/S larghezza 90 mm. 4_Guide per montaggio divano.
Imbottitura della struttura: 5_Poliuretano espanso a densità differenziate Olmo Polilatex T50-D, Olmo Polilatex T40-P e Olmo Polilatex T25.
6_Vellutino accoppiato 350 gr. con cotone accoppiato 3 mm.
Imbottitura dei cuscini: 7_Cuscini schienale in poliuretano espanso a densità differenziate Olmo PF 21/SM, Olmo PF 25/SM, Olmo PF 30/M e Olmo WLD 25/S.
8_Cuscini seduta con inserto in poliuretano espanso a densità differenziata Ecoelast 40, Olmo T40RC e Olmo Viscoelastico 40. 9_Termolegato con fodera di cotone 400 gr.
Rivestimento: 10_Rivestimento in pelle o in tessuto completamente sfoderabile.
Finiture: 11_Piedini in metallo verniciato colore bianco, brun sablé, grigio e nero.

Structure: 1_Fir wood frame. 2_Plywood panels. 3_Springing with elastic belts type Intes Elabelt 790/S width 90 mm. 4_Sofa assembly guide-rails.
Structure padding: 5_Differentiated density polyurethane foam: Olmo Polilatex T50-D, Olmo Polilatex T40-P and Olmo Polilatex T25.
6_Velveteen coupled 350 gr. with cotton fabric 3 mm.
Cushion padding: 7_Backrest cushions in differentiated density polyurethane foam: Olmo PF 21/SM, Olmo PF 25/SM, Olmo PF 30/M and Olmo WLD 25/S.
8_Seat cushions with insert in differentiated density polyurethane foam: Ecoelast 40, Olmo T40RC and Olmo Viscoelastic 40. 9_Heat-bonded with cotton lining 400 gr. **Cover:** 10_Fully removable leather or fabric cover.
Finishing: 11_Painted metal feet in the following finishes: white, sandy brown, grey and black.

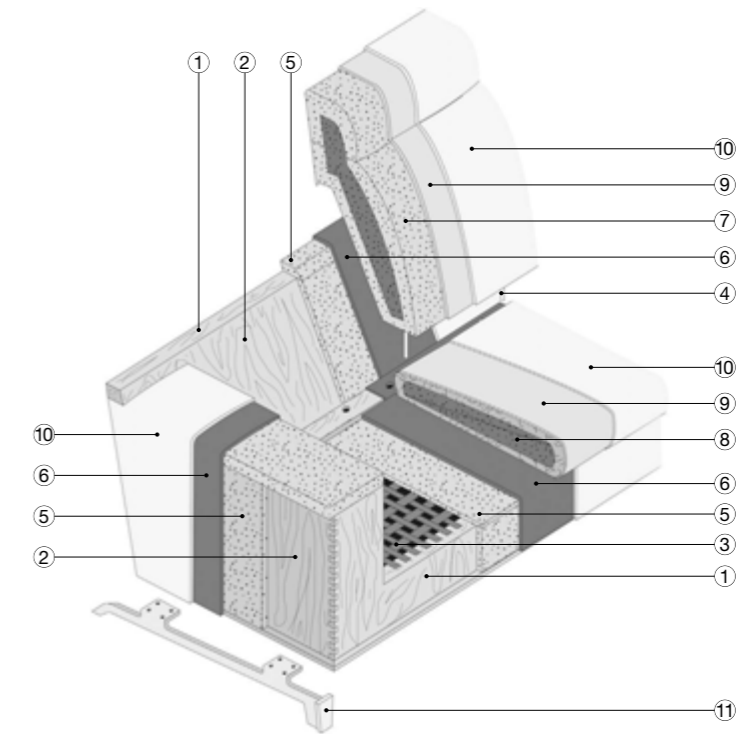

Composizione pagine 138/139

Poltrona Glee: rivestimento 1420/01-1 cat. EXTRA
 e piedini verniciati brun sablé

GLEE 687

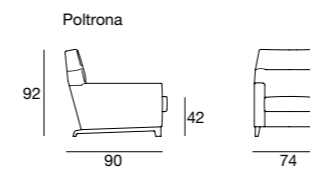

DIVA

design marconato&zappa

Struttura: 1_Structura in legno. 2_Molleggio ottenuto con cinghie elastiche Intes Elsbelt 790/4 larghezza 90 mm.

Imbottitura della struttura: 3_Poliuretano espanso a densità differenziate: sedile Olmo PF 40 + WLD 35/S + T 50/D, schienale ET 30 + EET 25 + T 40 + SR 75.

4_Accoppiato tessuto di cotone 100 gr.

Rivestimento: 5_Rivestimento in pelle o in tessuto completamente sfoderabile.

Finiture: 6_Basamento girevole in acciaio lucido o satinato oppure piedini in legno tinto.

Structure: 1_Wooden structure. 2_Spring action obtained with elastic belt Elsbelt 790/4 width 90 mm

Structure padding: 3_Multy-density expanded polyurethane: seat Olmo PF 40 + WLD 35/S + T 50/D, back ET 30 + EET 25 + T 40 + SR 75 PRS 100 gr.

4_Matching cotton fabric.

Cover: 5_Fully removable leather or fabric cover.

Finishing: 6_Base rounded in polished or brushed steel, or feet in tinted wood.

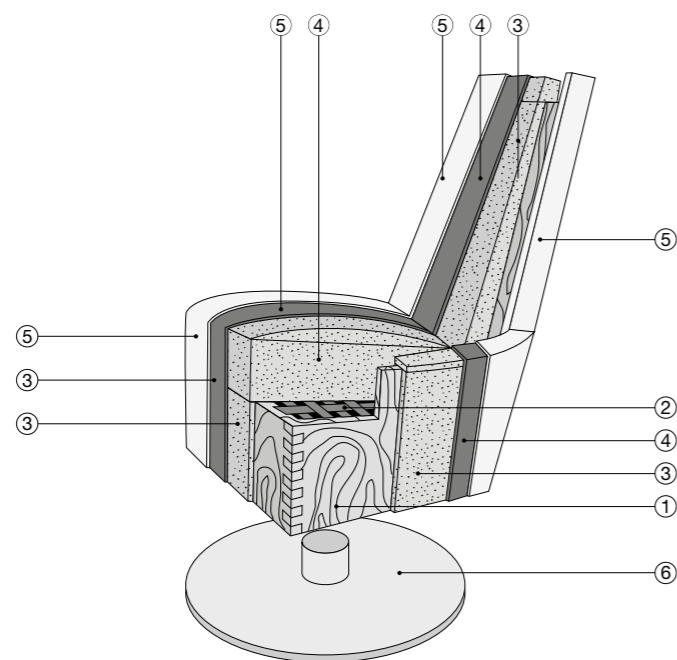

Composizione pagine 140/141

Poltrona Diva girevole: rivestimento 1020/100/4 EXTRA
basamento acciaio lucido

DIVA 640

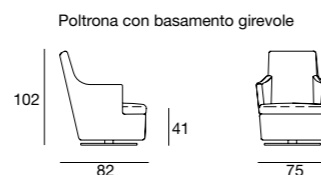
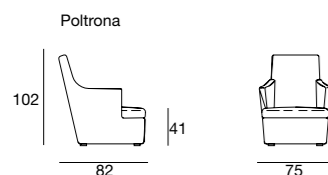

PASSION

design marconato&zappa

Struttura: 1_Structura in legno di abete. 2_Pannelli di legno compensato.

3_Molleggio ottenuto con cinghie elastiche Intes Elsbelt 790/S larghezza 90 mm.

Imbottitura della struttura: 4_Poliuretano espanso a densità differenziate Olmo POLILATEX 65 HD, Olmo HIGH COMFORT PF 21 SM e Olmo POLILATEX T 40 P.

5_Vellutino accoppiato TL 200 gr. e TL 100 gr. trapuntato rombetto grigio.

Imbottitura dei cuscini versione piuma: 6_Cuscino schienale in piuma, con inserto in poliuretano espanso a densità differenziata Olmo HIGH COMFORT PF 21 SM e Olmo D/25 SM. Rivestito con fodera di cotone. 7_Cuscino sedile in piuma, con inserto in poliuretano espanso a densità differenziata Olmo HIGH COMFORT PF 35 e Olmo POLILATEX T 40/P e Olmo B.S PF 35 FR. Rivestito con fodera di cotone.

Imbottitura dei cuscini versione poliuretano: 6_Cuscino schienale in poliuretano espanso a densità differenziata Olmo D/25SM e Olmo HIGH COMFORT PF 21 SM. Rivestito con fibra di Dacron accoppiata con cotone 400 gr. 7_Cuscino seduta in poliuretano espanso a densità differenziata Olmo HIGH COMFORT PF 35 e Olmo POLILATEX T 40/P e Olmo B.S PF 35 FR. Rivestito con fibra di Dacron accoppiata con cotone 400 gr.

Rivestimento: 8_Rivestimento in pelle o in tessuto completamente sfoderabile.

Finiture: 9_Piedini in legno di faggio tinto.

Structure: 1_Pinewood frame. 2_Pinewood panels.

3_Springing with elastic belts type Intes Elsbelt 790/S width 90 mm.

Structure padding: 4_Foamed polyurethane at differentiated densities Olmo POLILATEX 65 HD, Olmo HIGH COMFORT PF 21 SM and Olmo POLILATEX T 40 P.

5_Velveteen coupled TL 200 gr. and TL 100 gr. grey quilted rumber.

Cushions padding feather type: 6_Backrest in feather with foamed polyurethane insert at differentiated densities Olmo HIGH COMFORT PF 21 SM and Olmo D/25 SM. Covered with cotton fabric. 7_Seat cushion in feather with foamed polyurethane insert at differentiated densities Olmo HIGH COMFORT PF 35, Olmo POLILATEX T 40/P and Olmo B.S PF 35 FR. Covered with cotton fabric.

Cushion padding polyurethane type: 6_Backrest cushion in foamed polyurethane at various densities Olmo D/25SM and Olmo HIGH COMFORT PF 21 SM. Covered with Dacron fibre coupled with cotton 400 gr. 7_Seat cushion in foamed polyurethane at differentiated densities Olmo HIGH COMFORT PF 35, Olmo POLILATEX T 40/P and Olmo B.S PF 35 FR. Covered with Dacron fibre coupled with cotton 400 gr.

Cover: 8_Completely removable leather or fabric cover.

Finishing: 9_Feet in tinted beech-wood.

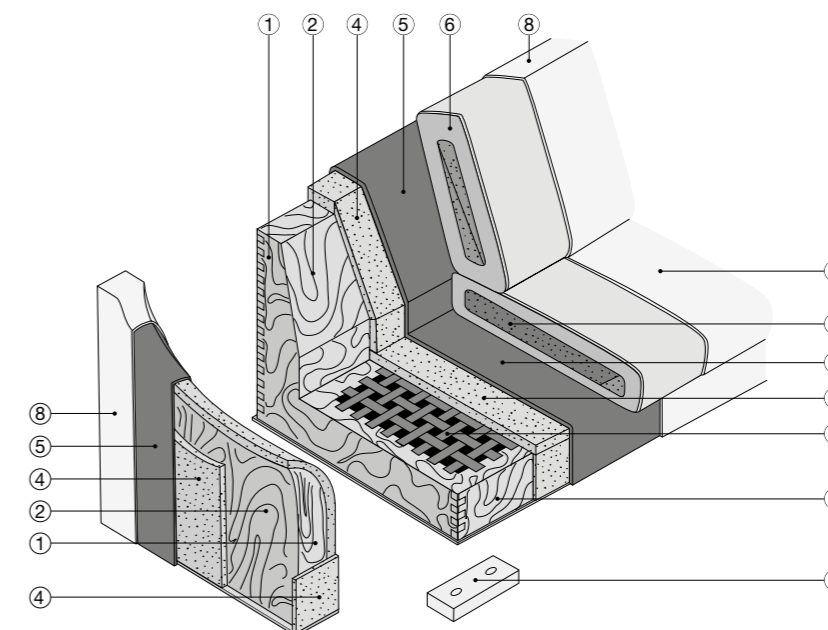

Composizione pagine 142/143

Poltrona Passion: rivestimento 1550/3-2 cat. EXTRA

PASSION 680/681

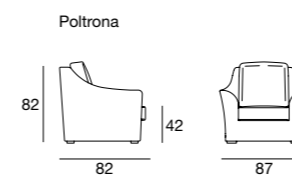

LIGHT_EASY

design marconato&zappa

Struttura: 1_Struttura in legno massello di abete. 2_Pannelli di legno compensato. 3_Pannelli di legno multistrati. 4_Molleggio ottenuto con cinghie elastiche Intes Elabelt 790/4 larghezza 90 mm.

Imbottitura della struttura: 5_Poliuretano espanso a densità differenziata T25 - PF30 - T40P - SR75. 6_Vellutino accoppiato con espanso mm 10 TL/SC 200 gr.

7_Accoppiato tessuto di cotone 100 gr. con vellutino.

Imbottitura cuscini versione piuma: 8_Cuscini schienali in piuma d'oca bianca etichetta standard Assopioma, con inserto in poliuretano espanso a densità differenziata PF21SM - PF25SM - T40. 9_Cuscini sedili in piuma d'oca bianca etichetta standard Assopioma, con inserto in poliuretano espanso a densità differenziata OS30FM - WLD35 - T40RC.

Imbottitura cuscini versione poliuretano: 8_Cuscini schienali in poliuretano espanso a densità differenziata PF21SM - PF25SM + termolegato 400gr. con fodera di cotone. 9_Cuscini sedili in poliuretano espanso a densità differenziata EM40 - OS30FM + termolegato 400gr. con fodera di cotone.

Rivestimento: 10_Rivestimento in pelle o in tessuto completamente sfoderabile.

Finiture: 11_Piedini in alluminio lucido oppure faggio naturale sbiancato o tinto: wengè, noce, noce scuro, ciliegio.

Structure: 1_Pinewood frame. 2_Plywood panels. 3_Multilayer panels.

4_Suspension obtained from 90 mm wide, Intes Elabelt 790/4 elastic belts.

Structure padding: 5_Differentiated density expanded polyurethane T25 - PF30 - T40P - SR75. 6_Velveten coupled with foamed polyurethane mm 10 TL/SC 200 gr. 7_Coupled cotton fabric 100 gr. with velveten.

Cushions padding goose down type: 8_Backrest cushions in white goose down Assopioma standard label with foamed polyurethane insert at differentiated densities PF21SM - PF25SM - T40. 9_Seat cushions in white goose down Assopioma standard label with foamed polyurethane insert at differentiated densities OS30FM - WLD35 - T40RC.

Cushions padding polyurethane type: 8_Backrest cushions in differentiated density expanded polyurethane PF21SM - PF25SM + heat bonded with 400 gr. cotton cover.

9_Seat cushions in differentiated density expanded polyurethane EM40 - OS30FM + heat bonded with 400 gr. cotton cover. **Cover:** 10_Completely removable leather or fabric cover.

Finishing: 11_Polished aluminium feet or beech-wood: natural bleached or tinted wengè, walnut, dark walnut, cherry.

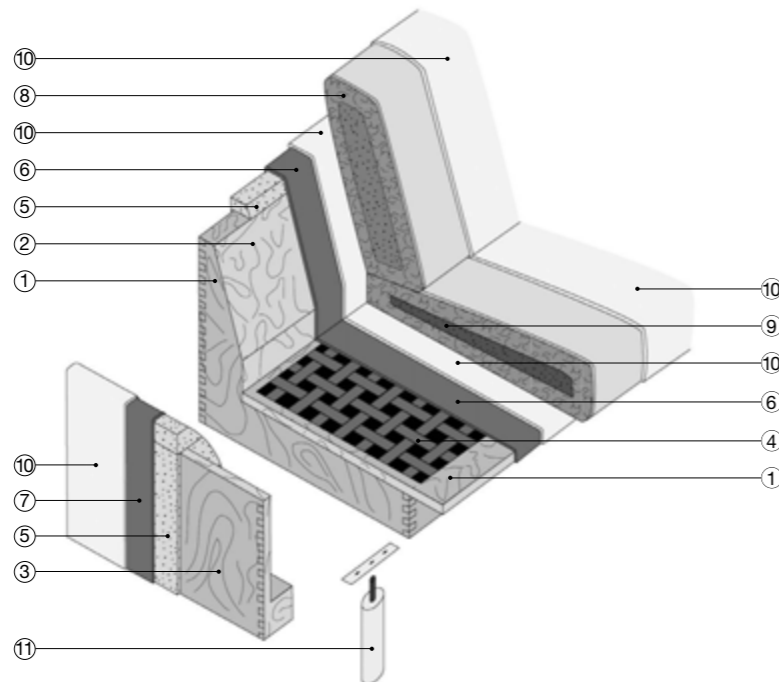

Composizione pagine 144/145

Poltrona Light: rivestimento 1300/01-3 cat. piedini alluminio lucido

Composizione pagine 146/147

Poltrona Easy: rivestimento 1610-105 cat. EXTRA

LIGHT 674/675

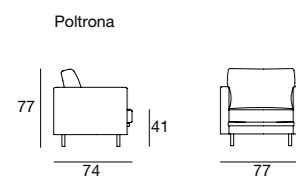

EASY 672/673

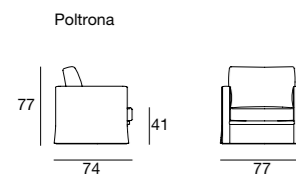

MOON

design marconato&zappa

Struttura: 1_Struttura in legno multistrati tamburato.

Imbottitura della struttura: 2_Sedile: poliuretano espanso a densità differenziata T40 - EM40 - MTP95. 3_Schienale: poliuretano espanso a densità differenziata PF30M - SR75 - agglomerato 160. 4_Resinato 100 gr. accoppiato con vellutino.

Rivestimento: 5_Rivestimento in pelle o in tessuto completamente sfoderabile.

Finiture: 6_Basamento in frassino naturale sbiancato o tinto wengè, noce, noce scuro, ciliegio e laccato bianco o nero.

Structure: 1_Multilayer frame.

Structure padding: 2_Seat: differentiated density expanded polyurethane T40 - EM40 - MTP95. 3_Backrest: differentiated density expanded polyurethane PF30M - SR75 - agglomerated 160. 4_Resin 100 gr. coupled with velveten.

Cover: 5_Completely removable leather or fabric cover.

Finishing: 6_Base in ash-wood: natural bleached or tinted wengè, walnut, dark walnut, cherry and white or black lacquered.

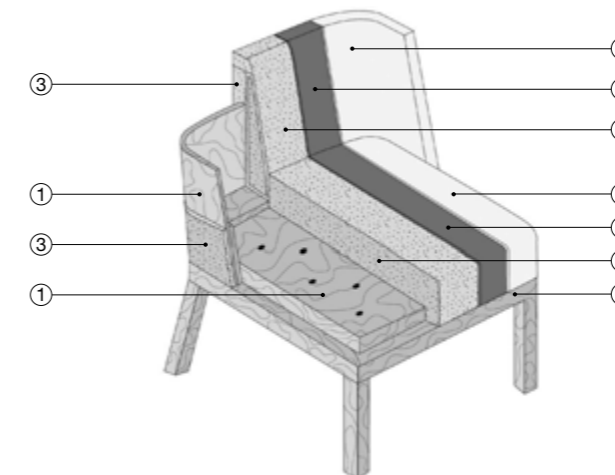

Composizione pagine 148/149

Poltrona Moon: rivestimento 1470/2003 cat. EXTRALUX basamento frassino tinto noce scuro

Composizione pagina 149

Poltrona Moon: rivestimento 1310/01 cat. H basamento frassino tinto naturale sbiancato

MOON 678

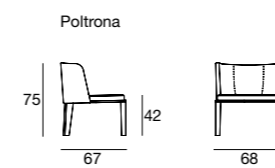

WELL

design marconato&zappa

Struttura: 1_Struttura in legno di abete. 2_Pannelli di legno compensato. 3_Molle ottenute con cinghie elastiche Intes Elasmat 790/4 larghezza 90 mm.

Imbottitura della struttura: 4_Poliuretano espanso a densità differenziate Olmo SR75, Olmo T40P e Olmo PF30. 5_Vellutino accoppiato TL 200 gr. e TL 100 gr. accoppiato 3 mm.

Imbottitura dei cuscini: 6_Cuscini schienale in poliuretano espanso a densità differenziate Olmo WLD 25/S e Olmo PS 25/SM termolegato 350 gr. e rivestiti con fodera di cotone per modello Well. Cuscini schienale in piuma rivestiti in fodera di cotone per modello WellSoft. 7_Cuscino seduta in poliuretano espanso a densità differenziate Olmo Ecoelast 40, Olmo T40RC e Olmo Viscoelastico 40 termolegato 350 gr. rivestito in fodera di cotone.

Rivestimento: 8_Rivestimento in pelle o in tessuto completamente sfoderabile.

Finiture: 9_Piedini in alluminio lucido, satinato o brunito.

Structure: 1_Fir wood frame. 2_Plywood panels. 3_Springing with elastic belts type Intes Elasmat 790/4 width 90 mm.

Structure padding: 4_Foamed polyurethane at differentiated densities Olmo SR75, Olmo T40P and Olmo PF30.

5_Velveten coupled TL 200 gr. and TL 100 gr. coupled 3 mm.

Cushion padding: 6_Backrest cushion in foamed polyurethane at differentiated densities Olmo WLD 25/S and Olmo PS 25/SM heat-bonded 350 gr. and with cotton lining for Well model. Backrest cushion in goose down covered with cotton lining for WellSoft model. 7_Seat cushion in foamed polyurethane at differentiated densities Olmo Ecoelast 40, Olmo T40RC and Olmo Visco-elastic 40 heat-bonded 350 gr. covered with cotton lining.

Cover: 8_Completely removable leather or fabric cover.

Finishing: 9_Feet in polished, satined or burnished aluminium.

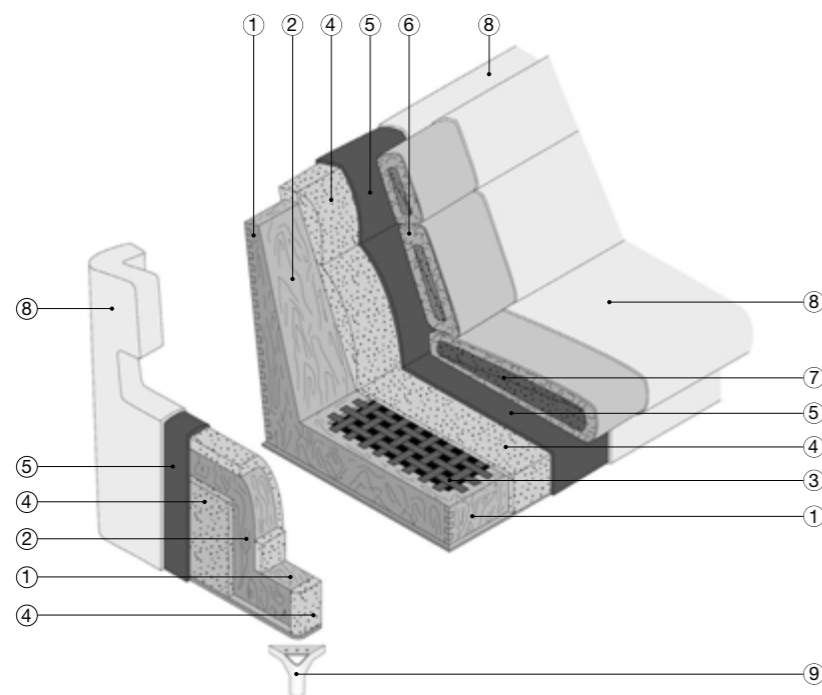

Composizione pagine 150/151

Poltrona Well: rivestimento 1470/2003 cat. EXTRALUX e piedini alluminio satinato

WELL 682

Poltrona

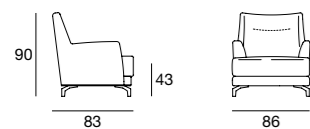

HOLA

design marconato&zappa

Struttura: 1_Struttura in legno di abete. 2_Pannelli di legno compensato.

3_Molle ottenute con cinghie elastiche Intes Elasmat 790/4 larghezza 90 mm.

Imbottitura della struttura: 4_Poliuretano espanso a densità differenziate sedile: Olmo T 25 N + T 30 N + T 50, schienale: Olmo T 25 N + ET 30 + T 50.

5_Rivestimento in resinato 100 gr. accoppiato cotone.

Rivestimento: 6_Rivestimento in pelle o in tessuto completamente sfoderabile.

Finiture: 7_Basamento cromato o verniciato, oppure rivestito in cuoio.

Structure: 1_Fir-wood structure. 2_Plywood panels.

3_Springing made with Intes Elasmat 790/4 elastic straps-width 90 mm.

Structure padding: 4_Multi-density expanded polyurethane for seat: Olmo T 25 N + T 30 N + T 50 Back: Olmo T 25 N + ET 30 + T 50.

5_Matching covers 100 gr. Heat compacted batting with cotton fabric.

Cover: 6_Fully removable leather or fabric cover.

Finishing: 7_Base in chrome or painted, alternatively leather-covered.

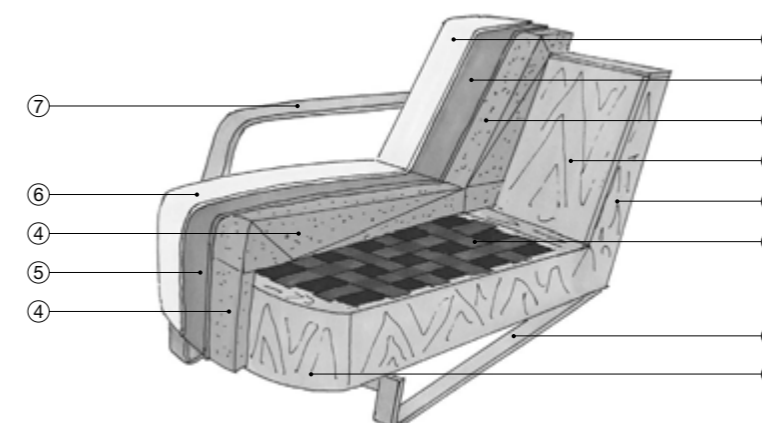

Composizione pagine 152/153

Poltrona Hola: rivestimento 1610-105 cat. EXTRA struttura cromata

HOLA 632

Poltrona

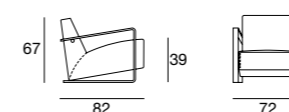

COCOON

design marconato&zappa

Struttura: 1_Pannelli in legno multistrati curvato.

Imbottitura della struttura: 2_Sedile: poliuretano espanso a densità differenziata T40 - T40P - EM40 (KPA39). 3_Schienale: poliuretano espanso a densità differenziata PF25SM - PF21SM - T40P - MPT95. 4_Resinato 100 gr. accoppiato con vellutino.

Rivestimento: 5_Rivestimento in pelle o in tessuto completamente sfoderabile.

Finiture: 6_Basamento in acciaio lucido oppure piedini in alluminio o in legno naturale sbiancato o tinto: wengè, noce, noce scuro, ciliegio.

Structure: 1_Bent multilayer frame.

Structure padding: 2_Seat: differentiated density expanded polyurethane T40 - T40P - EM40 (KPA39). 3_Backrest: differentiated density expanded polyurethane PF25SM - PF21SM - T40P - MPT95. 4_Resin 100 gr. coupled with velvetten.

Cover: 5 Completely removable leather or fabric cover.

Finishing: 6_Base in polished steel or feet in aluminium or wood: natural bleached or tinted wengè, walnut, dark walnut, cherry.

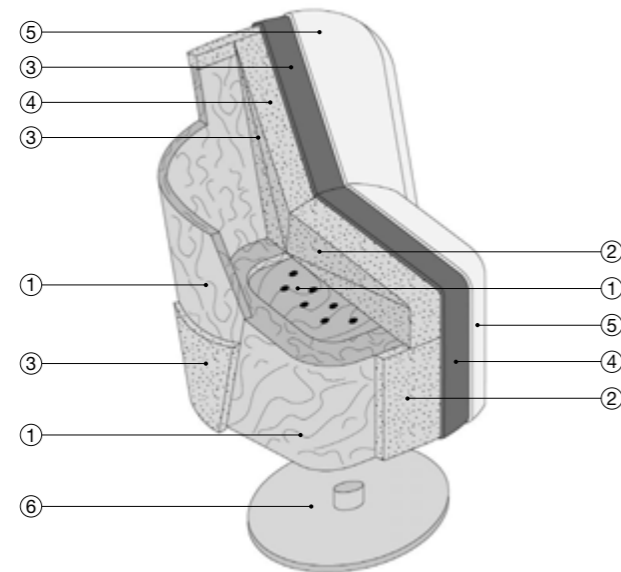

Composizione pagine 154/155

Poltrona Cocoon: rivestimento 1240/01 cat. G
basamento girevole acciaio lucido

COCOON 679

Poltrona con basamento girevole

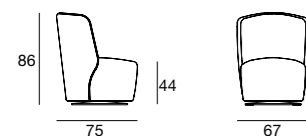

Poltrona

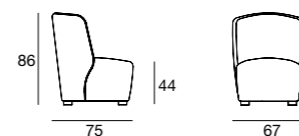

SELFY

design marconato&zappa

Caratteristiche: Tavolini che presentano originali piani in marmo Calacatta, marmo Emperador, marmo Portoro e in legno impiallacciato frassino tinto, elegantemente appoggiati a un'inedita base in metallo disponibile in finitura bronzo e ottonato anticato, verniciato bronzo scuro anodizzato e verniciato oro satinato.

Characteristics: Side tables, with original Calacatta marble, Emperador marble, Portoro marble and painted ash veneer tabletops, which elegantly rest on an innovative metal base available in a bronze, antique brass, painted dark bronze anodized and painted gold satin finish.

SELFY 707

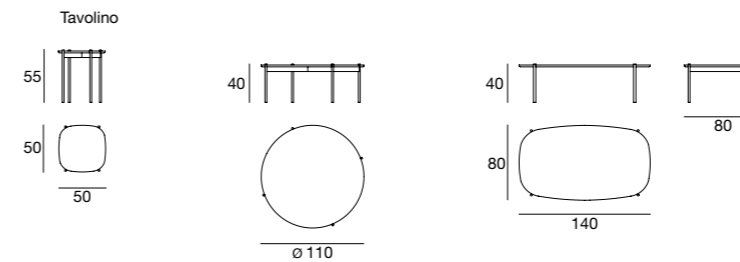

Varianti piani marmo



Calacatta

Emperador

Portoro

Varianti piani legno



Frassino naturale

Frassino tinto noce

Frassino tinto
noce scuro

Frassino tinto wengè

Frassino laccato
bianco poro aperto

Frassino laccato
nero poro aperto

Varianti basamento



Bronzo

Ottonato anticato

Verniciato bronzo
scuro anodizzato

Verniciato oro
satinato

CHARME

design marconato&zappa

Caratteristiche: Collezione caratterizzata da un'immagine importante e leggera grazie alla struttura della base in metallo in quattro finiture, bronzo, ottonato anticato, verniciato bronzo scuro anodizzato e verniciato oro satinato, che sostiene rigorosi piani d'appoggio in marmo nelle versioni Calacatta, Emperador e Portoro, e in legno impiallacciato frassino tinto.

Characteristics: A collection of side tables featuring a bold and light look thanks to the metal base in four finishes - bronze, antique brass, painted dark bronze anodized and painted gold satin finish - that support streamlined original Calacatta marble, Emperador marble, Portoro marble and painted ash veneer tabletops.

CHARME 708

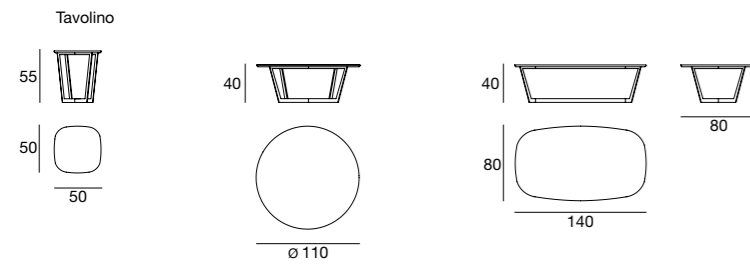

Varianti piani marmo



Calacatta

Emperador

Portoro

Varianti piani legno



Frassino naturale

Frassino tinto noce

Frassino tinto
noce scuro

Frassino tinto wengé

Frassino laccato
bianco poro apertoFrassino laccato
nero poro aperto

Varianti basamento



Bronzo

Ottonato anticato

Verniciato bronzo
scuro anodizzatoVerniciato oro
satinato

ELLIOT

design marconato&zappa

Caratteristiche: Tavolini con piano in marmo Calacatta, Emperador e Portoro. Basamento in frassino naturale, tinto noce, tinto noce scuro, tinto wengé, o laccato bianco poro aperto e laccato nero poro aperto.

Characteristics: Coffee tables with Calacatta, Emperador and Portoro marble tops. Base in ashwood natural, walnut, dark walnut or wenge stain or white or black open-pore lacquer.

ELLIOT 691

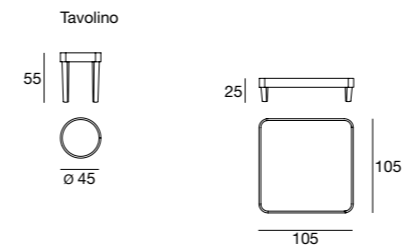

Varianti piani marmo

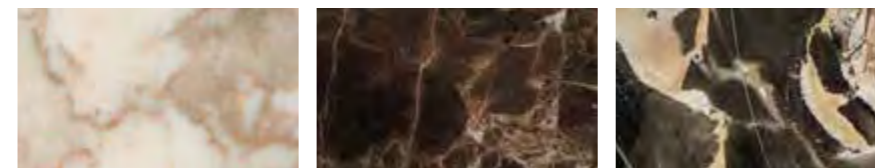

Calacatta

Emperador

Portoro

Varianti basamento



Frassino naturale

Frassino tinto noce

Frassino tinto
noce scuro

Frassino tinto wengé

Frassino laccato
bianco poro apertoFrassino laccato
nero poro aperto

CTS 2017

art direction_ **valentinicasarotti**associati
photo Master_ Fotografie
stylist_ Francesca Sassi, Donata Songia
fotolito_ CDcromo
stampa_ Grafiche Boffi

si ringrazia:
Fontana Arte
Casa del tappezziere Dell'Orto
Patrizia Cassina artista
Sforzin illuminazione
1380 Design and More
famiglia Usuelli_Bellusco

CTS
ITALIAN SOFAS

CTS SALOTTI SRL
Via Ada Negri, 5
20841 Carate Brianza (MB) ITALY
Tel. 0362 991038 r.a.
Fax 0362 991416
info@ctssalotti.com
www.ctssalotti.com

