

BAGUTTA

PREVIEW MILANO 2023



CTS
ITALIAN SOFAS

BAGUTTA

ATTRAVERSO GLI ELEMENTI MODULARI DI BAGUTTA È POSSIBILE CREARE UNA MOLTEPLICITÀ DI COMBINAZIONI, INVENTANDO INEDITI GIOCHI DI VOLUMI, SEGUENDO UN RITMO DI PIENI E VUOTI. LA LINEA AVVOLGENTE COME UN ABBRACCIO DEL DIVANO BAGUTTA NASCE DALLE FORME ERGONOMICHE PER REGALARE IL MASSIMO DEL COMFORT.

BAGUTTA PRENDE FORMA DALLA MATITA DEGLI ARCHITETTI MARCONATO & ZAPPA.

THROUGH THE MODULAR ELEMENTS OF BAGUTTA IT IS POSSIBLE TO CREATE A MULTIPLICITY OF COMBINATIONS, INVENTING UNPRECEDENTED PLAYS OF VOLUMES, FOLLOWING A RHYTHM OF SOLIDS AND VOIDS. THE ENVELOPING LINE, LIKE AN EMBRACE OF THE BAGUTTA SOFA, IS CREATED FROM ERGONOMIC SHAPES TO GIVE MAXIMUM COMFORT.

BAGUTTA TAKES SHAPE FROM THE PENCIL OF THE ARCHITECTS MARCONATO & ZAPPA.



BAGUTTA

BAGUTTA 01

SOFA

Design Marconato&Zappa
Cm. 330x350x71 h.



BAGUTTA 01

SOFA

Design Marconato&Zappa
Cm. 330x350x71 h.



BAGUTTA 02

SOFA

Design Marconato&Zappa
Cm. 325x105x71 h.



BAGUTTA 02

SOFA

Design Marconato&Zappa
Cm. 325x105x71 h.



BAGUTTA 03

SOFA

Design Marconato&Zappa
Cm. 370x150x71 h.



BAGUTTA 03

SOFA

Design Marconato&Zappa
Cm. 370x150x71 h.



BAGUTTA 04

SOFA

Design Marconato&Zappa
Cm. 240x105x71 h.



BAGUTTA 04

SOFA

Design Marconato&Zappa
Cm. 240x105x71 h.



BAGUTTA

Design Marconato&Zappa

Struttura: realizzata in legno di massello e multistrato. Il molleggio è ottenuto con cinghie elastiche larghezza mm 90.

Imbottitura: cuscini seduta e cuscini schienale in poliuretano espanso a densità differenziata densità 35 km 30 s 40 p rivestiti con fibra di dacron 150 gr.

Imbottitura dei cuscini versione piuma: cuscini in piuma d'oca sterilizzata con inserto in poliuretano densità differenziata densità 35 km 30 s 40 p rivestiti in pelle ovo di cotone.

Rivestimento: tessuto completamente sfoderabile.

Finiture: piedini in abs nero.

Frame: made in fir wood and multi-ply panels. The support system is created using 90 mm wide interwoven elastic straps.

Padding: seat cushions and back cushions in polyurethane foam with differentiated density 35 km 30 s 40 p covered with dacron 150 gr.

Padding goose down: seat cushions and back cushions in sterilized goose down with polyurethane insert differentiated densities 35 km 30 s 40 p covered in cotton muslin.

Cover: completely removable fabric.

Finishes: feet in black abs.

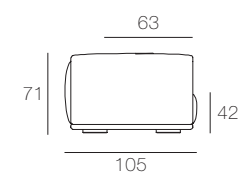

Divani_Sofas

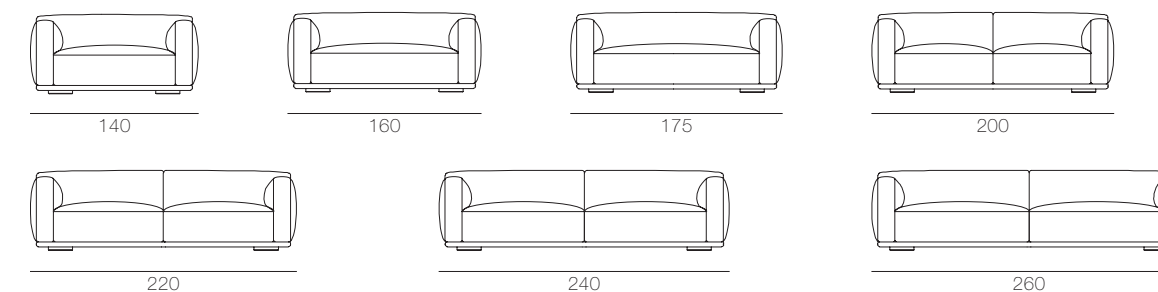

Divano bracciolo sx/dx_Sofas with 1 arm left/right

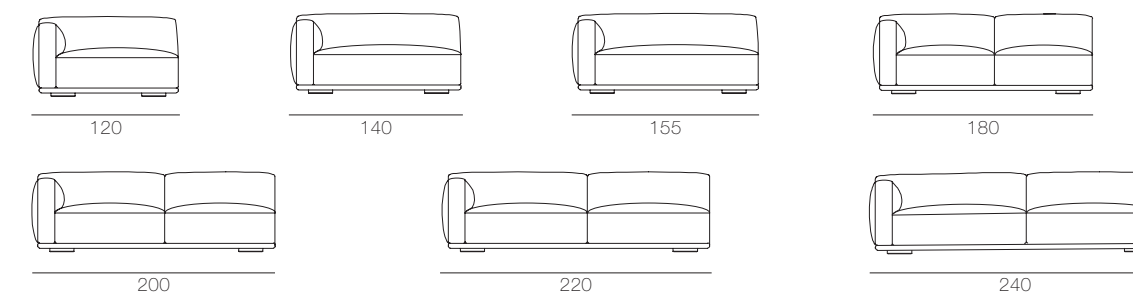

Elemento centrale divano_Central element for sofa

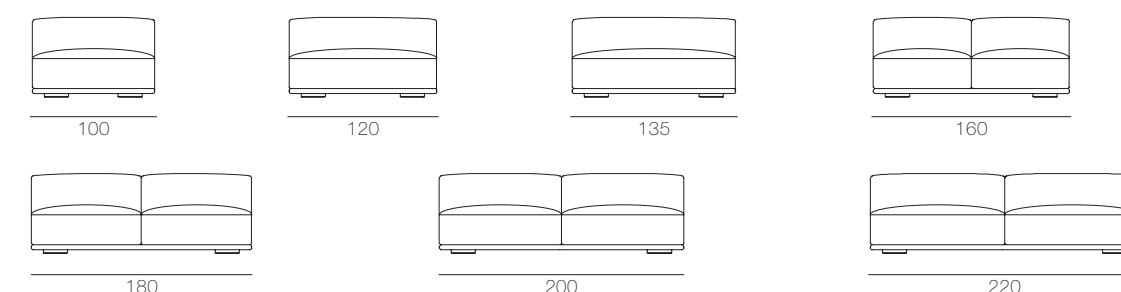

Cuscino_Cushion

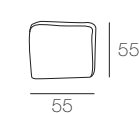

Elemento centrale tondo
Round central element

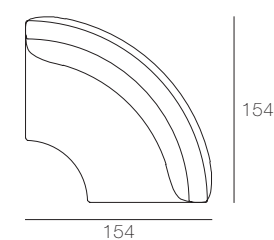

Angolo retto
Right corner

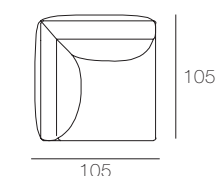

Pouff_Pouf

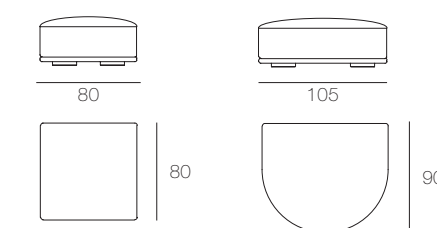

Elemento tavolino_Element side table

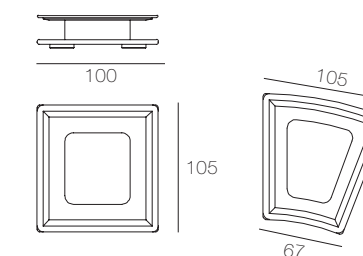

Chaise longue sx/dx_Chaise longue left/right

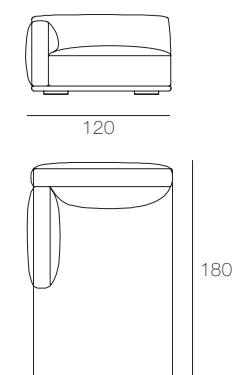

Elemento penisola sx/dx
Peninsula left/right

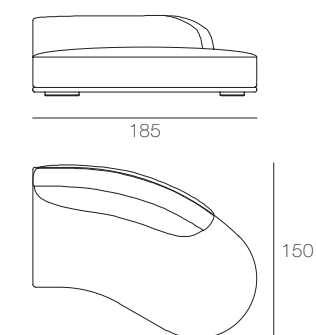

Elemento panca_Element bench

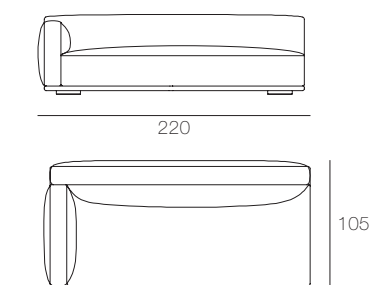

Elemento centrale inclinato
Inclined central element

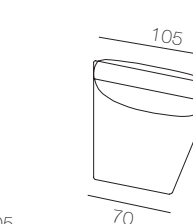

MARGOT

Design Marconato&Zappa

Struttura: realizzata in legno di Abete e pannelli in legno multistrato curvato. Molleggio ottenuto con cinghie elastiche Intes Elasebelt 790/4 larghezza mm 90.

Schienale e sedile: in poliuretano espanso a densità differenziata T30 e T40. Poliuretano a densità differenziata T21 SM e T40 P. Resinato 100gr. accoppiato con vellutino. Cuscino poggiatesta T25 rivestito in fodera di cotone.

Rivestimento: tessuto completamente sfoderabile.

Basamento: la poltrona è disponibile in due versioni, con basamento o con piedini. I piedini in metallo disponibile nelle seguenti finiture: verniciato Oro, Brun Sablè, Nero, Grigio. Basamento in Frassino naturale o tinto Wengè, Noce, Noce scuro, laccato a poro aperto Bianco, e laccato a poro aperto Nero.

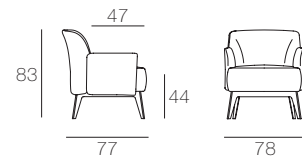

Frame: Fir wood and bent multi-ply panels. Elastic webbing suspension (90mm wide, Intes Elasebelt 790/4).

Backrest and seat: seat in differentiated density polyurethane foam (T30 and T40). Differentiated density polyurethane foam (T21 SM and T40 P). Resin (100gr) coupled with velveteen. Lower back cushion (T25) covered with cotton lining.

Cover: fully removable fabric.

Base: the sofa comes in two versions, with base or with feet.

Aluminium feet available in the following finishes: painted in satin Gold, Brun Sablè, Black and Grey. Base in Ash wood – Natural or Wengè, Walnut, dark Walnut stain and with white or Black open-pore lacquered.

JACK

Design Marconato&Zappa

Struttura: realizzata in legno massello di Frassino tinto o Noce Canaletto.

Finitura struttura: in legno Frassino tinto o laccato nei colori disponibili o Noce Canaletto.

Schienale e sedile: in poliuretano espanso a densità differenziata T40 e T25 rivestiti con resinato 150gr/mq accoppiato con vellutino con inserto in multistrato.

Rivestimento: in pelle, Nabuk o tessuto non sfoderabile.

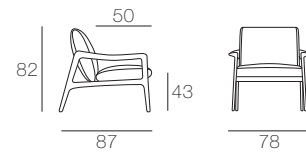

Frame: stained solid Ash or Canaletto Walnut.

Frame finish: stained or lacquered Ash wood in the available colours or Canaletto Walnut.

Backrest and seat: T40 and T25 differentiated density polyurethane foam covered with 150gr/m2 resin coupled with velveteen with multi-ply insert.

Cover: not removable leather, Nubuck or fabric.

GUEST

Design Marconato&Zappa

Struttura: realizzata in legno massello e multistrato curvato.

Rivestimento struttura: in legno Frassino tinto nei colori disponibili o Noce Canaletto.

Imbottitura: in poliuretano a densità differenziata T35 e T40 e rivestiti con resinato 150gr./mq accoppiato con vellutino.

Rivestimento: in pelle, Nabuk o tessuto, non sfoderabile.

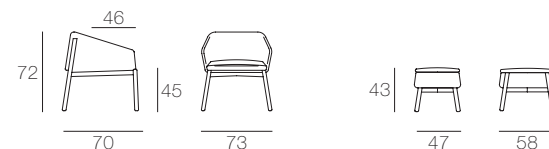

Frame: stained solid Ash or Canaletto Walnut and bent multi-ply.

Frame finish: stained or lacquered Ash wood in the available colours or Canaletto Walnut.

Backrest and seat: T35 and T40 differentiated density polyurethane foam covered with 150gr/m2 resin coupled with velveteen.

Cover: not removable leather, Nubuck or fabric.

TAPE

Design Marconato&Zappa

Struttura: realizzata in legno massello curvato di Frassino tinto nei colori disponibili o Noce Canaletto.

Piano: realizzato in marmo Calacatta, Emperador, Portoro o Sahara noir od in gres porcellanato finitura Calacatta o Nero Marquinia.

Frame: curved solid Ash wood stained in the available colours or Canaletto Walnut.

Top: Calacatta, Emperador, Portoro or Sahara Noir marble, or in porcelain stoneware with Calacatta or Marquinia Black finish.

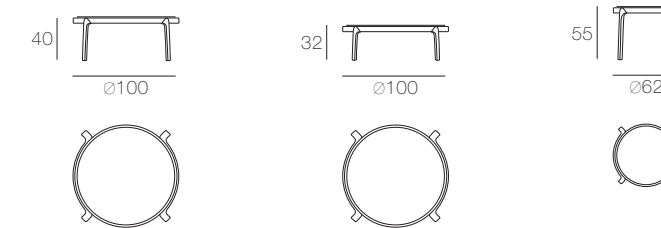

DOMINO

Design UT. CTS salotti

Struttura: realizzata in multistrato di Abete.

Imbottitura: in poliuretano espanso.

Rivestimento: in pelle, Nabuk o tessuto non sfoderabile.

Il pouff domino è disponibile in quattro versioni con e senza basamento e con piano superiore o senza.

Basamento: realizzato in legno Faggio tinto o laccato nei colori disponibili.

Piano superiore: realizzato in gres porcellanato finitura Calacatta o Nero Marquinia.

Frame: fir multi-ply.

Padding: polyurethane foam

Cover: not removable leather, Nubuck or fabric.

The domino pouf is available in four versions with and without base and with or without top.

Base: stained or lacquered beech wood in the available colours.

Upper top: available in Calacatta or Marquinia Black porcelain stoneware.



TRESOR

Design UT. CTS salotti

Struttura: realizzata in multistrato di Abete.

Imbottitura: in poliuretano espanso con lavorazione a capitonnè.

Rivestimento: in pelle, Nabuk o tessuto.

Frame: fir multi-ply.

Padding: polyurethane foam with button-tufting.

Cover: leather, Nubuck or fabric.

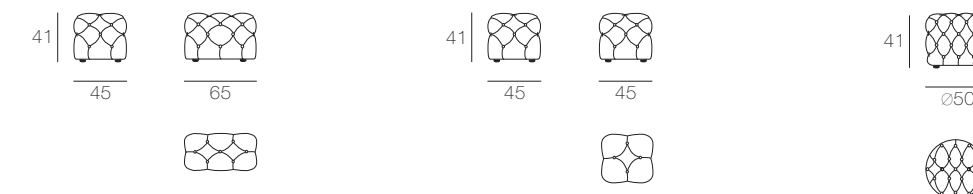

Credits:

AD: Galvani&Tremolada

Ph: Master Fotografie

Print: Grafiche Boffi

Si ringrazia:

SIRECOM TAPPETI ITALIA

Data la nostra politica aziendale di continua implementazione e miglioramento dei nostri prodotti, le dimensioni e le caratteristiche tecniche degli stessi potrebbero variare in qualsiasi momento, secondo le esigenze tecnico e commerciali, e ciò senza l'obbligo di preavviso e senza possibilità di rivendicazione da parte dell'acquirente.

Le illustrazioni, i dati e le descrizioni contenuti in questo catalogo non sono quindi impegnativi ed hanno solo valore indicativo.

La tecnica di stampa può determinare differenze di colore. Per una corretta valutazione di tonalità e colore è necessario fare riferimento ai campioni fisici. In ogni caso, i materiali quali metalli, tessuti, pelli, marmi ed essenze possono essere oggetto di naturali ed inevitabili differenze di tonalità e di venatura rispetto al campione fisico.

Nessuna parte di questo catalogo, testo o fotografia può essere riprodotta o trasmessa in qualsiasi forma o tramite mezzo elettronico o meccanico, comprese le fotocopie, senza previo permesso scritto da parte della società CTS SALOTTI.

Due to the company policy of continuous implementation and improvement of our product, dimensions and technical characteristics may vary at any time, according to technical and commercial requirements. These variations may occur without obligation of warning and without the possibility of claim by the buyer. The illustrations, data and descriptions contained in this catalogue are therefore to be considered as an indication of the final products.

Printing methods can determine colour differences. For a correct evaluation of tone and colour it is necessary to refer to the physical samples. In any case, materials such as metal, fabrics, leather, marble and wood may be subject to natural and inevitable differences in tone and grain compared to the physical sample.

No part of this catalogue, text or photograph may be reproduced or transmitted in any shape or form, through electronic or paper-based communication, including photocopies, without the prior express written consent of CTS SALOTTI.

CTS
ITALIAN SOFAS

Via Ada Negri, 5_Carate Brianza (MB)
Italy +39 0362 991038
info@ctssalotti.com_www.ctssalotti.com

