

# HOLA

design marconato&zappa

Poltrona caratterizzata da basamento cromato o verniciato, oppure rivestito in cuoio. Rivestimento in pelle o tessuto completamente sfoderabile.

Armchair characterized by base in chrome or painted, alternatively leather-covered. Fully removable leather or fabric cover.



## WELL

design marconato&amp;zappa

**Struttura:** 1\_Struttura in legno di abete. 2\_Pannelli di legno compensato. 3\_Molle ottenute con cinghie elastiche Intes Elabest 790/4 larghezza 90 mm.

**Imbottitura della struttura:** 4\_Poliuretano espanso a densità differenziate Olmo SR75, Olmo T40P e Olmo PF30. 5\_Vellutino accoppiato TL 200 gr. e TL 100 gr. accoppiato 3 mm.

**Imbottitura dei cuscini:** 6\_Cuscini schienale in poliuretano espanso a densità differenziate Olmo WLD 25/S e Olmo PS 25/SM termolegato 350 gr. e rivestiti con fodera di cotone per modello Well. Cuscini schienale in piuma rivestiti in fodera di cotone per modello WellSoft. 7\_Cuscino seduta in poliuretano espanso a densità differenziate Olmo Ecoelast 40, Olmo T40RC e Olmo Viscoelastico 40 termolegato 350 gr. rivestito in fodera di cotone.

**Rivestimento:** 8\_Rivestimento in pelle o in tessuto completamente sfoderabile.

**Finiture:** 9\_Piedini in alluminio lucido, satinato o brunito.

**Structure:** 1\_Fir wood frame. 2\_Plywood panels. 3\_Springing with elastic belts type Intes Elabest 790/4 width 90 mm.

**Structure padding:** 4\_Foamed polyurethane at differentiated densities Olmo SR75, Olmo T40P and Olmo PF30.

5\_Velveten coupled TL 200 gr. and TL 100 gr. coupled 3 mm.

**Cushion padding:** 6\_Backrest cushion in foamed polyurethane at differentiated densities Olmo WLD 25/S and Olmo PS 25/SM heat-bonded 350 gr. and with cotton lining for Well model. Backrest cushion in goose down covered with cotton lining for WellSoft model. 7\_Seat cushion in foamed polyurethane at differentiated densities Olmo Ecoelast 40, Olmo T40RC and Olmo Visco-elastic 40 heat-bonded 350 gr. covered with cotton lining.

**Cover:** 8\_Completely removable leather or fabric cover.

**Finishing:** 9\_Feet in polished, satined or burnished aluminium.

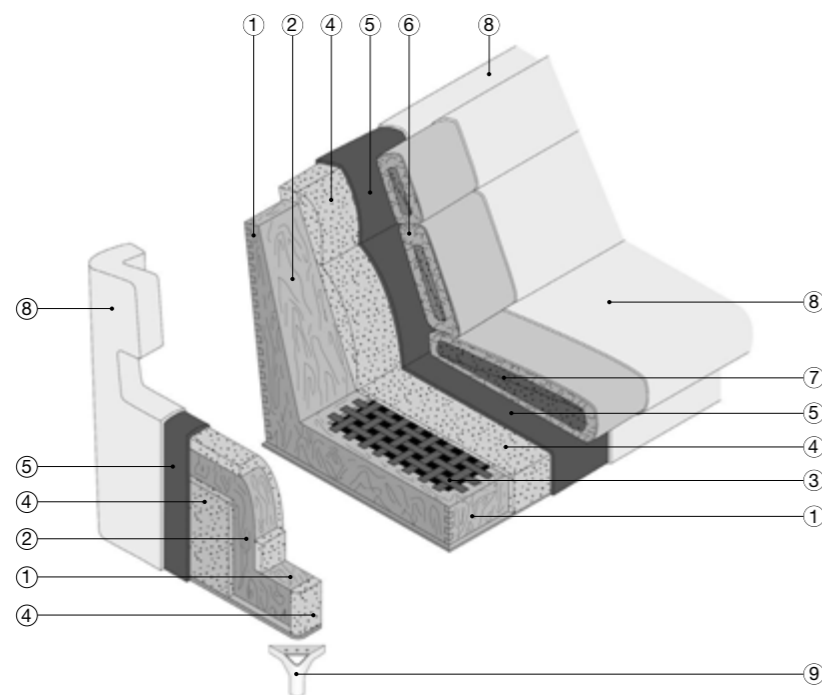

## Composizione pagine 150/151

Poltrona Well: rivestimento 1470/2003 cat. EXTRALUX e piedini alluminio satinato

## WELL 682

Poltrona

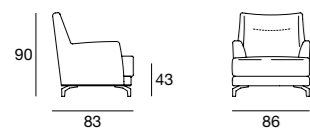

## HOLA

design marconato&amp;zappa

**Struttura:** 1\_Struttura in legno di abete. 2\_Pannelli di legno compensato.

3\_Molle ottenute con cinghie elastiche Intes Elabest 790/4 larghezza 90 mm.

**Imbottitura della struttura:** 4\_Poliuretano espanso a densità differenziate sedile: Olmo T 25 N + T 30 N + T 50, schienale: Olmo T 25 N + ET 30 + T 50.

5\_Rivestimento in resinato 100 gr. accoppiato cotone.

**Rivestimento:** 6\_Rivestimento in pelle o in tessuto completamente sfoderabile.

**Finiture:** 7\_Basamento cromato o verniciato, oppure rivestito in cuoio.

**Structure:** 1\_Fir-wood structure. 2\_Plywood panels.

3\_Springing made with Intes Elabest 790/4 elastic straps-width 90 mm.

**Structure padding:** 4\_Multi-density expanded polyurethane for seat: Olmo T 25 N + T 30 N + T 50 Back: Olmo T 25 N + ET 30 + T 50.

5\_Matching covers 100 gr. Heat compacted batting with cotton fabric.

**Cover:** 6\_Fully removable leather or fabric cover.

**Finishing:** 7\_Base in chrome or painted, alternatively leather-covered.

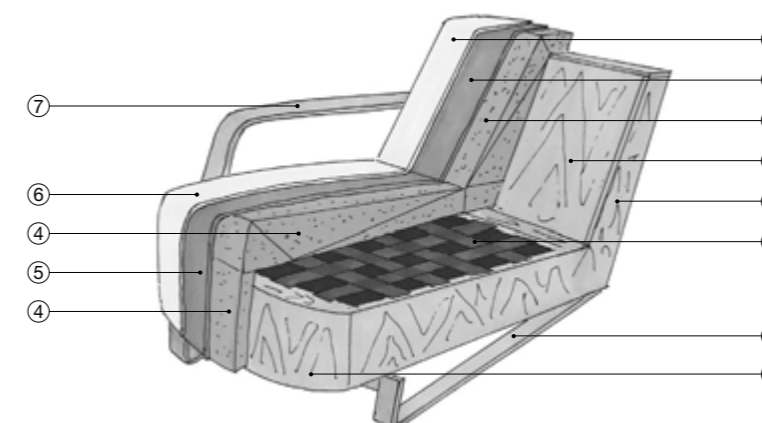

## Composizione pagine 152/153

Poltrona Hola: rivestimento 1610-105 cat. EXTRA struttura cromata

## HOLA 632

Poltrona

